



ePowerControl

PV/Diesel/Grid integration
Controller



User Manual

Product installation instructions

HFS-S

Index

General information	4
About this manual	4
Glossary	4
Legal information	5
Safety warnings	5
Scope of supply	6
The ePowerControl Controller	6
Additional equipment	7
Monitoring platform - ePowerMonitor	7
Operating modes	7
Grid-tied mode	7
Islanded mode	7
Back-up mode	8
Commissioning overview	8
Before proceeding to the commissioning	8
Deployment steps	9
Step 2: Communication Architecture Plan	10
Objectives	10
RS485 Constraints: Configuring Slave ID Addresses	10
Ethernet Constraints: Configuring IP Addresses	10
Example	11
Step 3: Wire the slave devices	12
Connecting RS485 Devices	12
Central Computing Unit serial ports	12
Wiring	13
Termination of data wires	14
Shield	14
Connecting Ethernet Devices	15
Central Computing Unit LAN ports	15
Wiring	16
Wiring an AC Meter 5A provided by Elum	16
Materials required	16
Safety Warnings	17
Installation location	17
Device overview	18
Installation steps	18
Wiring an AC Meter 333mV provided by Elum	24

Materials required	24
Safety Warnings	24
Installation location	24
Device overview	25
Installation steps	25
Step 4: Configuring non-Elum equipment	30
Configuring Solar Inverters	30
Configuring Genset Controllers	31
Configuring Grid and Load Sensors	33
Step 5: Installing the ePowerControl	35
Installation	35
Instructions the ePowerControl is delivered in a casing	35
Instructions the ePowerControl is delivered as a kit	35
Power Supply	35
Instructions for connecting the power supply to ePowerControl when in Elum casing	36
Instructions for connecting the power supply to ePowerControl when in kit	36
Step 6: Configuring the ePowerControl on Elum Configuration	38
Before proceeding to the commissioning	38
Required Materials	38
Prerequisite	38
Accessing Elum Configuration	38
Configuring your password	38
Configuring site settings	39
Configuring data forwarding (optional)	40
Export FTP	41
Energysoft	41
USB Export	42
Configuring internet access	43
Configuring a wired internet connection	43
Configuring a cellular internet connection	45
Configuring ports and devices	48
Configuring your EMS	55
Starting data acquisition and EMS	57
Step 7: Functional tests	60
Test environment configuration	60
EMS status	60
PV injection	60
Devices connection status	60

Consistency check up	61
Test procedures	61
On-Grid (PV + Grid application)	61
Islanded (PV + Genset)	63
Backup (PV + Genset + Grid)	64
Tests conclusion	66
On-Grid (PV + Grid application) test matrix	66
Islanded (PV + Genset) test matrix	67
Backup (PV + Genset + Grid) test matrix	68
Elum Configuration after the commissioning	70
Accessing Elum Configuration	70
Elum Configuration Overview panel	70
Genset controller widget	70
Solar inverter widget	70
Power meter widget	71
Controller widget	71
Elum Configuration menus	71
Devices	72
Version	74
Control	74
Network	76
Date	76
Password	77
Site	78
Data Forwarding	79
Advanced	79
Appendix A: New equipment driver integration by Elum	81
Objectives	81
Integration procedures	81
Non-critical device	82
Critical device	82
Appendix B: Ten mistakes to avoid	85
Appendix C: Internet Speed Test	90
Internet Speed Test Requirements for Elum Explorers	90
Test protocol to be performed	90

1. General information

1.1. About this manual

The purpose of this manual is to provide the users with **all the necessary information to install, configure and operate the ePowerControl ZE, ePowerControl SD and ePowerControl HFS products by Elum Energy**. It includes product information, safety instructions, installation and configuration guidelines. For the ePowerLog DL, please see the dedicated User Manual. For the ePowerControl MC and ePowerControl PPC, please refer to the Elum team.

This document is dedicated to:

- EPC of new hybrid PV/Genset or PV/Battery power systems
- EPC of PV/Battery power systems on existing genset based power systems
- Anyone involved in the design, installation and maintenance of hybrid power systems

The two following symbols will help the reader navigate through the document by highlighting important information from the general text:



Warning

A Warning sign indicates a hazardous situation that could result in death or serious injury. It will often involve precaution and guidelines to avoid it.



Notes

Notes provide general information for the reader to keep in mind.



Please make sure to read this manual before installing the ePowerControl to avoid any human injury and equipment damage

1.2. Glossary

APN address	Gateway between a GSM, GPRS, 3G or 4G mobile network and another computer network
AWG (12 wires)	American wire gauge
CT	Current Transducers detect electric current in a wire & generate a proportional signal
DHCP mode	Dynamic Host Configuration Protocol to assign IP addresses
DIN rail	Standard metal rail used for mounting industrial control equipment inside equipment racks
EMS	Energy Management System

EPC	Company that handles the Engineering, Procurement & Commissioning of projects
I/O module	Input/Output module
ICMP	Internet Control Message Protocol
LAN ports	Ports for a Local Area Network
Local NEC rules	National Electrical Code
Modbus RTU	Communication protocol to connect a supervisory computer with a remote terminal unit (RTU)
Modbus TCP	Communication protocol to connect a supervisory computer with a remote terminal unit through Ethernet with a transmission control protocol (TCP)
RS-485	Standard electrical characteristics of drivers and receivers in serial communications systems
SCADA	Supervisory control and data acquisition
SNMP	Simple Network Management Protocol (SNMP) is an Internet Standard protocol for collecting and organizing information about managed devices on IP networks and for modifying that information to change device behavior.
UDP ports	Ports for User Datagram Protocol
UPS	Uninterruptible power supply, providing emergency power to a load when the input power source or mains power fails

1.3. Legal information

The company Elum SAS, whose registered office is located at 9 rue d'Enghien - 75010 PARIS and registered with the Paris Trade and Companies Registry under number 817 860 083, integrates and distributes monitoring and control panels for photovoltaic and hybrid installations marketed under the names "ePowerLog" and "ePowerControl".

Elum guarantees its controllers meet the quality standards used in France, that they are designed and integrated in France and that they meet the technical criteria and quality requirements.

The content of this document can be edited by Elum. The English version of the document prevails if any discrepancy appears in a translated version.

1.4. Safety warnings

Elum ePowerControl products are electrical equipment. The installation and operation should only be conducted by authorized personnel aware of the risks involved.



Installation of meters

Voltage-carrying parts. Risk of heart attack, burns and other injuries. Disconnect the power supply and charge the device before installing the analyzer. Protect

the terminals with covers. The energy analyser must be installed by qualified/approved personnel.

**Dangerous voltage**

Do not touch the terminals for voltage and current measurement. Always connect grounding terminals. Do not disconnect the controller CT terminals. Be careful to protect the unit from electrostatic discharges during the installation.

**Internet access**

A stable internet access is required to perform the commissioning of ePowerControl controllers
(Cf. [Appendix C: Internet Speed Test](#))

**Monitoring and control features**

Elum can only guarantee the monitoring and control of the site according to its product features once all of the equipment to be monitored and controlled have correctly been configured and connected to the controller.

**Reverse Power Protection (for the ePowerControl SD, HFS, MC and PPC)**

The ePower Control is NOT an electrical protection. It does not replace an adequate protection of diesel generators against power reversal, nor a properly configured/installed protection relay, nor a properly configured/installed genset controller integrating the reverse current protection functionality. If necessary, please install protection relays against reverse power.

1.5. Scope of supply

1.5.1. The ePowerControl Controller

The ePowerControl is ready-to-use and consists of a Central Computing Unit and one or more satellites. The central unit integrates control algorithms and provides remote communication with the Elum cloud via the Internet. Any option purchased by the client for the controller will already be implemented into the base station.



For more information regarding the Computer Central Unit, please refer to your ePowerControl datasheet.

1.5.2. Additional equipment

Additional external equipment (such as weather sensors, I/O modules, or power meters) included in the purchase order will be delivered following the same terms as the controller. Some of those equipment will already be embedded in the ePowerControl cabinet, while others will have to be installed by the client. Please see the [Options](#) section for more information.

1.5.3. Monitoring platform - ePowerMonitor

Once all the different equipment are installed, the internet connection of the controller configured and the commissioning tests performed, Elum will give the client access to the online monitoring platform (User ID & Password).

1.6. Operating modes

1.6.1. Grid-tied mode

The Grid-tied mode refers to a power system with PV + Grid, in a configuration similar to this:

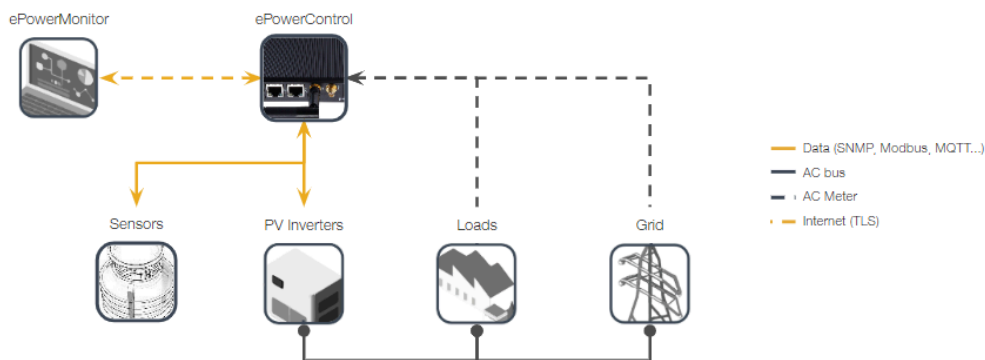

Fig. 1: Diagram of the grid-tied mode

1.6.2. Islanded mode

The Islanded mode refers to a power system with PV + Genset, in a configuration similar to this:

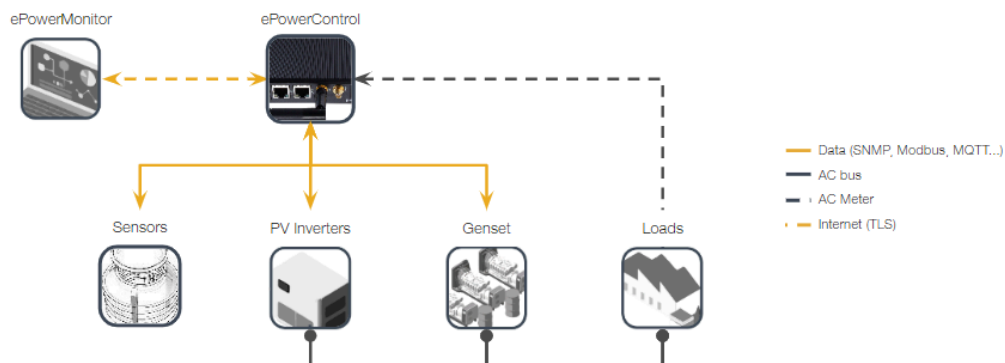

Fig. 2: Diagram of the islanded mode

1.6.3. Back-up mode

The Back-up mode refers to a power system with PV + Genset + Grid, in a configuration similar to this:

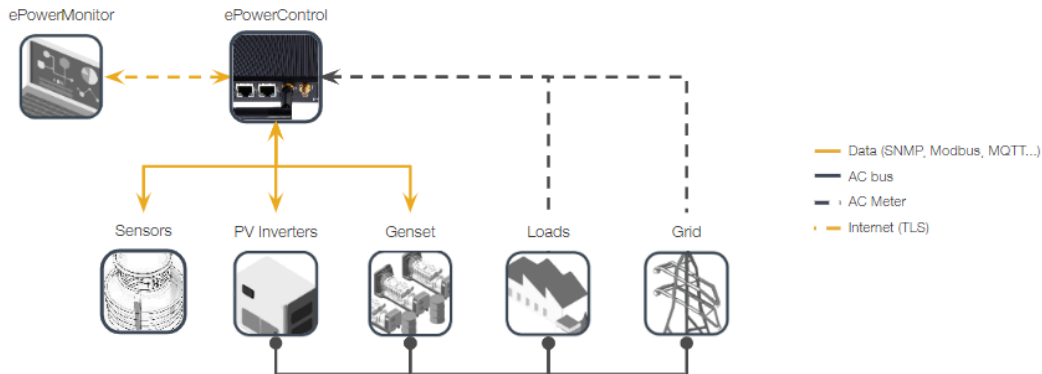

Fig. 3: Diagram of the back-up mode

1.7. Commissioning overview

1.7.1. Before proceeding to the commissioning

Prior to the commissioning, the following documents will be sent by Elum:

- User Manual
- Datasheet
- Device Connection & Configuration Specific Instructions

The ePowerControl controller delivered to you was pre embedded with Elum last up to date EMS firmware and is ready to install. The installation team should follow the instructions available in this document for the autonomous commissioning of the controller. The complete configuration of your system can be done on site and all the information needed for the commissioning of the system is included in this document.



Equipment first integration by Elum

For new equipment integration by Elum, you must follow instructions given in Appendix of this User Manual.

[Cf. Appendix A: New equipment driver integration by Elum](#)



PV injection

All the deployment process should be done with the PV injection shutdown. Elum cannot be held responsible if uncontrolled PV injection causes damage during the deployment process.

1.7.2. Deployment steps

✓	Step 1	Read the User Manual
	Step 2	Plan the communication architecture
	Step 3	Wire the slave devices
	Step 4	<p>Connect and configure all non-Elum equipment:</p> <ul style="list-style-type: none"> - PV inverters - Generator controller (with a protection relay if necessary) - Power meters - Other equipment (sensors, Electric Vehicle Charging Stations, etc.)
	Step 5	Wire and install the ePowerControl
	Step 6	<p>Configure the ePowerControl online with Elum Configuration:</p> <ul style="list-style-type: none"> - ePowerControl password and Internet access - Communication ports and devices according to your Communication Architecture Plan (test and correct) - Operating mode - Start the Energy Management System and the data acquisition
	Step 7	Functional tests
	Step 8	(Optional) access to ePowerMonitor

2. Step 2: Communication Architecture Plan

2.1. Objectives

The communication plan should be ready before proceeding to the commissioning to avoid any communication issues related to the design of the network. The network design should take into consideration communication protocols wiring limitation and each device communication setup options.



Please note that LAN port n°2 of the Central Computing Unit cannot be used for monitoring and control purposes, it can be used merely to connect your computer and access to Elum Configuration .

2.2. RS485 Constraints: Configuring Slave ID Addresses



Every device should have a unique slave ID



All units connected to the same serial port should use the same communication protocol and the same parameters (Baud rate, parity, byte size and stop bits).



With Modbus RTU protocol, up to 32 units can be connected to the same serial communication port.



Limits

The total length of the cable must not exceed 1200 m.

2.3. Ethernet Constraints: Configuring IP Addresses



Every device should have a unique IP address
Every device must be in the same sub-network as the Elum Explorer
The sub-network **cannot** be 192.168.4.XX, which is reserved for configuration over LAN port n°2.



The following Subnet Mask should be configured on each device: 255.255.255.0



Limits

The total length of the cable must not exceed 300 m.

2.4. Example

Table 1: Communication Architecture Plan Example

Device	Slave Reference	Protocol	Slave IP address	Slave ID	Baud rate	Byte Size	Parity	Stop Bit
<i>Inverter n°1</i>	<i>SMA STP 25000 TL</i>	<i>Modbus TCP</i>	<i>192.168.3.200</i>	-	-	-	-	-
<i>Inverter n°2</i>	<i>SMA STP 25000 TL</i>	<i>Modbus TCP</i>	<i>192.168.3.201</i>	-	-	-	-	-
<i>Inverter n°3</i>	<i>SMA STP 25000 TL</i>	<i>Modbus TCP</i>	<i>192.168.3.202</i>	-	-	-	-	-
<i>Inverter n°3</i>	<i>SMA STP 25000 TL</i>	<i>Modbus TCP</i>	<i>192.168.3.203</i>	-	-	-	-	-
<i>Grid Meter</i>	<i>EM330-DIN .AV5.3.H.S 1.X, Carlo Gavazzi</i>	<i>Modbus RTU</i>	-	2	9600	8	No	1
<i>Load Meter</i>	<i>EM330-DIN .AV5.3.H.S 1.X, Carlo Gavazzi</i>	<i>Modbus RTU</i>	-	1	9600	8	No	1

3. Step 3: Wire the slave devices

3.1. Connecting RS485 Devices

Establishing a physical connection between ePowerControl and an equipment by RS485 allows ePowerControl to monitor and control this equipment by communicating via Modbus RTU. ePowerControl will then be the master of the communication bus while the rest of the connected equipment will be the Slaves. It is therefore necessary to configure each of them as such.

3.1.1. Central Computing Unit serial ports

Compatible RS485 devices can be connected to serial port 1 or 2 of the ePowerControl Central Computing Unit using two shielded twisted pair connectors. When an RS485 Extension has been provided by Elum, serial ports 1 or 2 of this one can also be used.

For third party hardware specific details please refer to the hardware provider documentation.

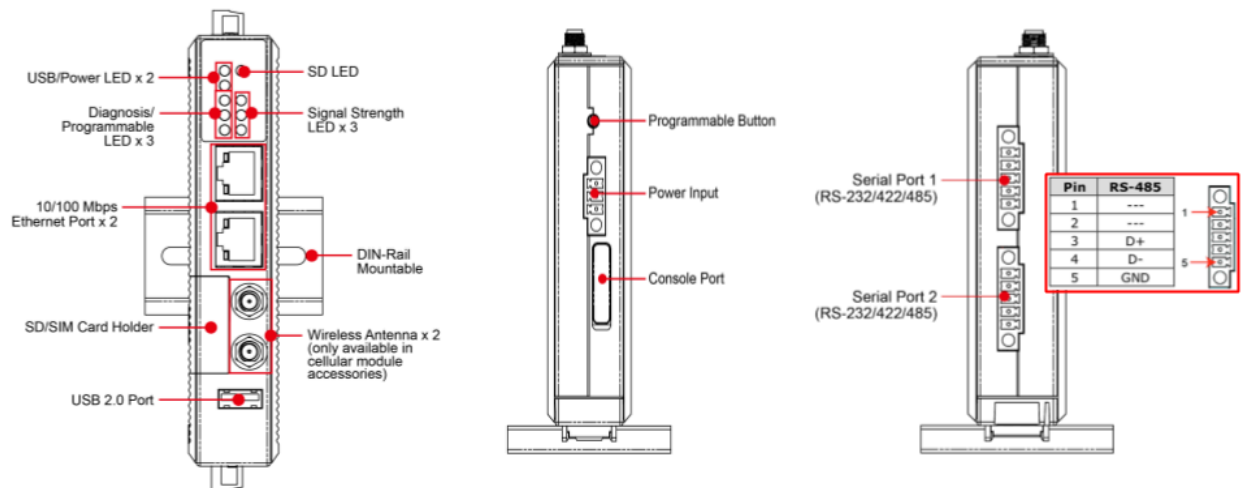
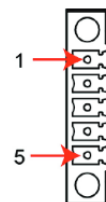

Fig. 4: Front, top and bottom views of the Central Computing Unit

Following table gives the Central Computing Unit pin attribution ports:

Table 2: Pins and communication port attribution

Pin	RS-232	RS-422	RS-485
1	TXD	TXD+	---
2	RXD	TXD-	---
3	RTS	RXD+	D+
4	CTS	RXD-	D-
5	GND	GND	GND





The correct identification of serial ports and pins is key to avoid communication issues. Also, a wrong wiring can damage communication ports. Please refer to the following picture as a reference if you have any doubts:

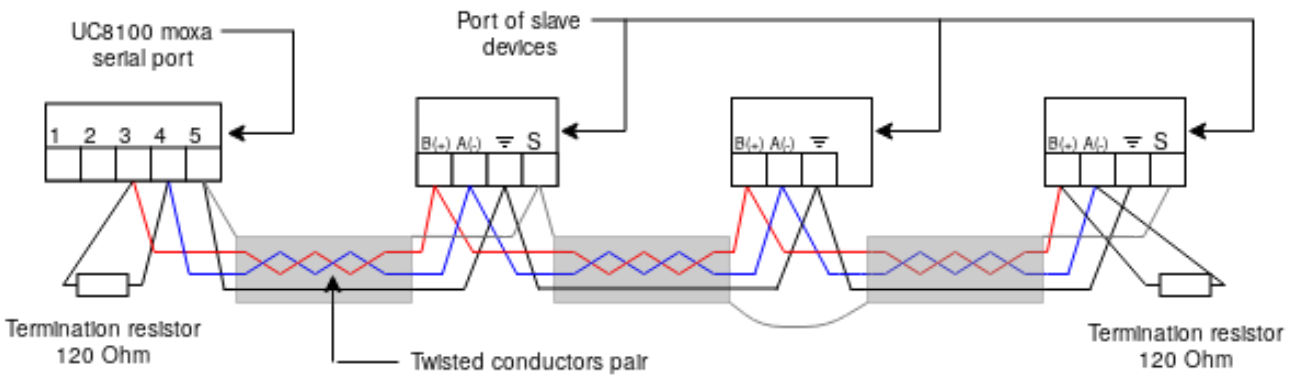
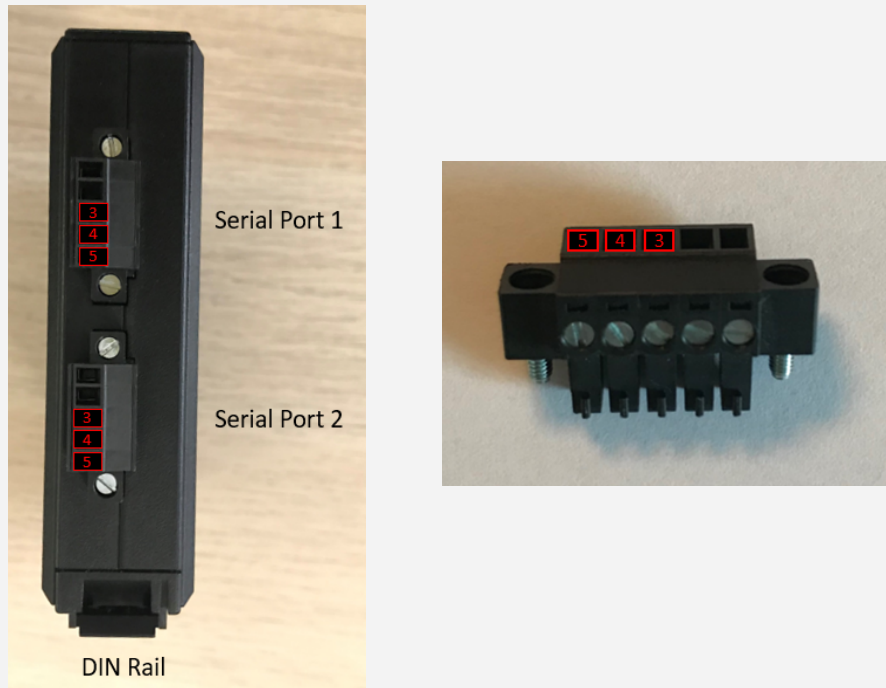

Fig. 5: Daisy-chain for RS-485 serial communication

3.1.2. Wiring

The wiring of the RS-485 serial line should be done according to the following guidelines:

1. The pin 3 of the serial port should be connected in a daisy-chain with all the dataB(+) port on the devices to be connected.

2. The pin 4 of the serial port should be connected in a daisy-chain with all the dataA(-) port on the devices to be connected.
3. The dataB(+) and dataA(-) should be a twisted pair of wires in order to prevent electromagnetic generated interferences.
4. The pin 5 of the serial port should be connected in a daisy-chain with all the GND port on the devices to be connected.

To ease the cabling and prevent errors, it is suggested to maintain a constant color scheme for the different communication wires (example: red for all the daisy chained dataB(+) wires, blue for all the daisy chained data(-) wires and black for all the daisy chained GND wires).

3.1.3. Termination of data wires

To terminate the data wire it is needed to install at each end of the line termination resistors connecting the dataB(+) and dataA(-) (as indicated in the figure). The termination resistors should have impedance compatible with the communication cable impedance (usual value 120 Ohm).

3.1.4. Shield

For the RS-485 lines, It is suggested to use shielded wires.

In this instance the shield should be electrically continued throughout all the serial line and connected to the GND wire of the RS-485 circuit at the controller (meaning pin 5).

To prevent ground loops it must be avoided to have multiple connections of the shield to the ground, the only connection of the shield and other wires should be at the level of the controller with the GND wire as before mentioned.

The use of unshielded data wires should be minimized to limitate eventual interferences.

In the following main restriction to the use of the RS-485 are reported:

- Up to 10 devices may be connected to a single port by daisy-chaining RS-485 connections.
- For each port, the total length of cable between the controller and the farthest external device may be up to 1.2km of RS-485-compatible cable.



Failure to follow all the instructions hereinabove, including the need for termination resistors, proper grounding and shielding, will result in unreliable communication with external devices, worsened performance, and possibly danger of damage to equipment.



Shield continuity must be provided along the communication line using dedicated on the third party hardware to connect, and must be grounded at a single point.



For lines longer than 100m, the use of a 120 Ohms termination resistance is strongly recommended. In this case, the resistance must be placed between the D+ and D- ports of the Central Computing Unit RS485 port.

3.2. Connecting Ethernet Devices

Establishing a physical connection between ePowerControl and Ethernet equipment allows ePowerControl to monitor/control this equipment by communicating via Modbus TCP/IP or SNMP. ePowerControl will then be the master of the communication bus while the rest of the connected equipment will be the Slave. As a matter of fact It is therefore necessary to configure each of them as such.

3.2.1. Central Computing Unit LAN ports

To connect power units or sensors using an ethernet connection (with Protocols such as Modbus TCP or SNMP), use the LAN ports of the ePowerControl module using an Ethernet-male to Ethernet-male cable.

If no Ethernet switch (optionally included in the box) is used, devices using Modbus TCP or SNMP protocol must be connected to one of the 2 LAN ports of the controller using an Ethernet-male to Ethernet-male cable.

If an Ethernet switch is used, devices using Modbus TCP must be connected to one of the free Ethernet ports of the switch, and one of the ports of the switch must be connected to the ePowerControl controller.

Front View

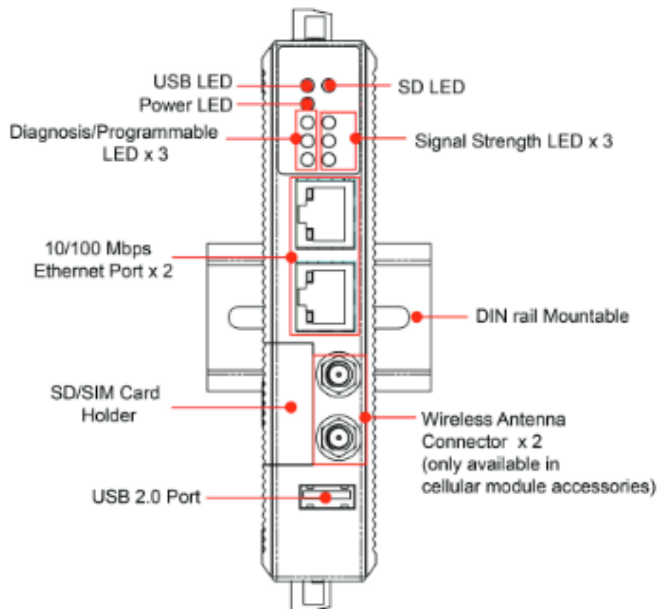

Fig. 6: Front view of the Central Computing Unit

The two 10/100 Mbps Ethernet ports of the Central Computing Unit and the switches provided by Elum use RJ45 connectors.

Pin	Signal
1	ETx+
2	ETx-
3	ERx+
6	ERx-

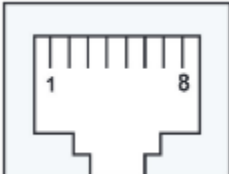

Fig. 7: Pin description of the LAN ports of the Central Computing Unit

3.2.2. Wiring

The wiring of the Ethernet line should be done by connecting each of the Slaves to the ePowerControl using an RJ45 cable

3.3. Wiring an AC Meter | 5A provided by Elum

3.3.1. Materials required

The installation and wiring of an AC Meter | 5A provided by Elum requires:

- Per phase: Use of proper smallest available breakers or rated fuse taps for the installation per local NEC rules. Usually 15A circuit breaker or single multipole breaker depending on phases used.

- Black, red, and white stranded AWG 12 wire; length depending on installation location. Thermal resistance to at least 75 C. Blue wire is needed in addition for 3-phase installations. Use wire that has insulation rating greater than the max voltage inside the panel. Note: wire colors may vary based on country and electrical service. Blue wire is needed in addition for 3-phase installations.
- Electrical tape
- Conduit and couplings as needed
- Mounting and wire organization hardware as needed
- If installed outside, appropriately rated enclosure

3.3.2. Safety Warnings



Please follow the installation instructions in this manual for wiring diagram and proper selection of CTs.

To reduce the risk of electric shock:

Do not connect the device to a circuit operating at > 277 Vrms to neutral.

- Always open or disconnect circuits from Power Distribution System of building before installing or servicing the unit or attached current transformers
- Only connect authorized 5A CTs to the CT inputs of the device

3.3.3. Installation location

The power meter must be installed near the low voltage distribution where there is easy access to the grid, load and genset connections (see application overview). A 10 A circuit-breaker shall be included (one per phase) in close proximity of the device and within easy reach of the operator. The breakers shall be marked as the disconnecting device for the power meter. The power meter is a listed device and must be installed inside a suitable enclosure. The enclosure the power meter is installed in must be rated according to the environment it is used in. For example, outdoor installations require an outdoor-rated enclosure. Select an installation location that is not exposed to direct sunlight of the elements.

3.3.4. Device overview

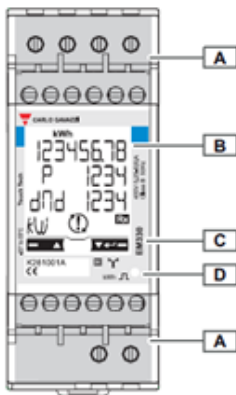

Area	Description
A	Current and communication connection terminals
B	Backlit LCD display with sensitive touch screen areas
C	Model, feature summary and serial number
LED:	
D	<ul style="list-style-type: none"> blinking red: pulse weight proportionate to the TA and TV ratio result, orange on: total active power negative. Control only run if the imported and exported energies are measured separately (Measure = b).

Fig. 8: View of the EM330-DIN.AV5.3.H.S1.X, Carlo Gavazzi

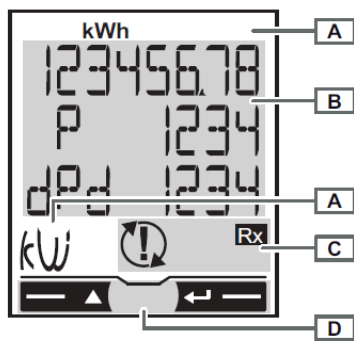

Area	Description
A	Unit of measure area
B	Specific section information area
Signal area:	
C	: incorrect voltage connections
	: incorrect current connections
	: version S1 only. Modbus command correctly received.
	: version S1 only. Modbus command correctly sent to master.
D	Command area

Fig. 9: View of the EM330-DIN.AV5.3.H.S1.X, Carlo Gavazzi LCD screen

3.3.5. Installation steps

1. Install the breaker(s) in the power-distribution panel so that they provide access to all phases.
2. Open the breakers so there is no power on the breaker contacts.
3. Mount the power meter inside a suitable enclosure near the power distribution panel.
4. Proceed to the wiring of the power meter and CTs according to the wiring diagram corresponding to the site system layout. For a three-phase system current, 4-wire, unbalanced load and three current transformers the wiring should be as described below. *Ensure that the stickers on the CTs point towards what is being measured. If it is necessary to shorten or lengthen the CT wires, ensure that the CT wires are properly connected.*



The main voltage must not exceed 400V, and the CTs must always have 5A secondary current.

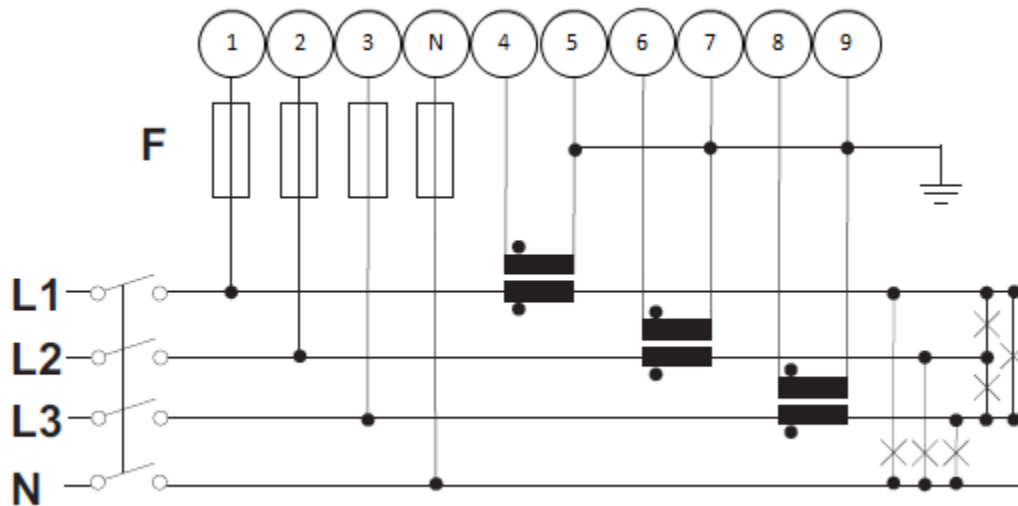

Fig. 10: Example of the EM330-DIN.AV5.3.H.S1.X, Carlo Gavazzi connection diagram for a three-phase system of the system, 4 wires, unbalanced load and three current transformers (CT) and three voltage transformers (VT)

5. Proceed to the power supply wiring of the power meter as described below.



The power supply should be 90-260 V AC/DC.



The auxiliary power supply on the meter enables it to always be powered up whether the plant is operating on grid or on gensets. Power meters monitoring the grid, the load or gensets should always be powered up. One of those power meters being suddenly turned off would turn the ePowerControl into a fail safe mode, curtailing PV production.

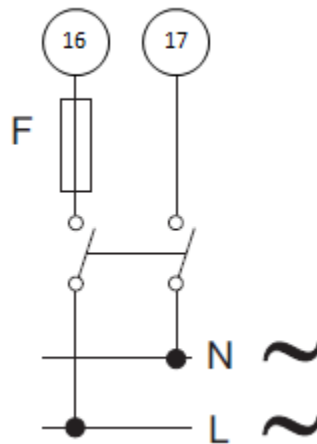

Fig. 11: Connecting the power supply to the EM330-DIN.AV5.3.H.S1.X, Carlo Gavazzi

6. Close the newly installed breakers. This should cause the power meter to power up, within a few seconds the screen should light up and display the measurement page.
7. You can now proceed to the parameter setup of the power meter.



When installing a EM330-DIN.AV5.3.H.S1.X, Carlo Gavazzi the critical parameters to be set are listed below:

SYStEM, System type: To be set according to the site design

Ct rAtIo, Current transformer ratio: To be set according to the CTs used with the power meter. You can obtain this ratio by dividing the primary current by the secondary current. As an example, when using 200 A to 5 A CTs, the ratio should be set to 40.

Vt rAtIo, Voltage transformer ratio: To be set according to the VTs used with the power meter. You can obtain this ratio by dividing the primary voltage by the secondary voltage. As an example, when installing the power meter using no VTs, the ratio should be set to 1.

MEASurE, Measurement type: To be set to “b”

AddrESS, Modbus address: To be set according to your ID plan



The result of the ratio between the current and voltage transformers must be under 1054.



It is critical that the measurement type was correctly set up to “b” for the zero export control feature. If the ePowerMeter was not correctly set up, Elum cannot guarantee any reliability on the zero export feature and will not be taken responsible if some energy is exported to the grid.



Instructions to use the power meter and navigate through the different menus.

Measurement pages displayed by default when turned on. Pages are characterized by the reference unit of measure. The initial measurement page set is displayed after 120 s of disuse.

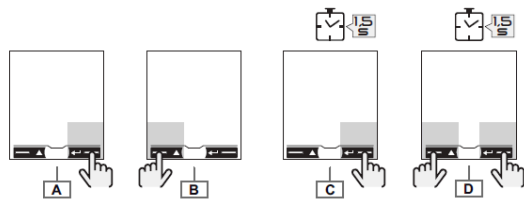

Commands

Navigation

Operation	Command
View the next page	A
View the previous page	B
Open the programming section	C
Exit the programming section	C (page End)
Open the information section	D
Exit the information section	D

Parameter settings

Operation	Command
Increase a parameter value	A
View the next value option	A
Decrease a parameter value	B
View the previous value option	B
Confirm a value	C
Open the parameter settings page	C



Parameters description

Page	Code	Description	Values
PASS	P1	Enter current password	Current password. 0000 default password.
nPASS	P2	Change password	Four digits (0000–9999)
SYStEM	P3	System type	3Pn : three phase system, 4-wire/ 3P : three-phase system, 3-wire/ 2P : two-phase system, 3-wire
Ct rAtIo	P4	Current transformer ratio (TA)	1–1000 *
Vt rAtIo	P5	Voltage transformer ratio (TV)	1–1000 *
NOTE *: the result of the ratio between the current and voltage transformers must be under 1054 for AV5 analyzers and under 3148 for AV6.			
MEASurE	P6	Measurement type	A : easy connection, measures total energy without considering the direction/ b : separately measures imported and exported energy
InStALL	P7	Connection check	On : enabled/ Off : disabled
P int	P8	Average power calculation interval (minutes)	1–30
MODe	P9	Display mode	Full : complete mode/ Easy : reduced mode. Measurements not displayed are still sent via serial port.
tArIFF	P10	Tariff management	On : enabled/ Off : disabled
HoME	P11	Measurement page displayed when turned on and after 120 seconds of disuse	For full display mode (Mode = Full): 0–19 For reduced display mode (Mode = Easy): 0–3, 6, 7, 10/11, 18 To learn the page code see " Measurement (Fig. 16) " on page 7.
rESET	P17	Enable energy tariff, maximum requested power and partial active and reactive energy reset (the latter only sent via serial port)	No : cancel reset/ Yes : enable reset
End	P18	Return to the initial measurement page	–
AddrESS	P14	Modbus address	1–247
bAUd	P15	Baud rate (kbps)	9.6/ 19.2/ 38.4/ 57.6/ 115.2
PArITY	P16	Parity	Even/ No
STOP bit	P16–2	Only if no parity. Stop bit.	1/ 2

8. Proceed to the communication wiring of the power meter as described below. Connect the ePowerMeter using a shielded twisted pair RS485 connector to one of the serial ports of the Central Computing Unit using a Cat 5 cable.

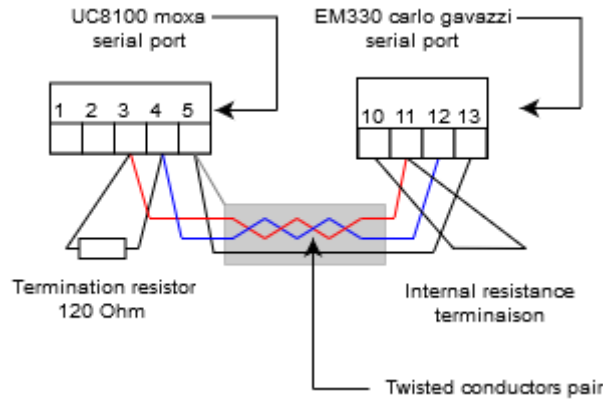

Fig. 12: Connecting a single EM330-DIN.AV5.3.H.S1.X, Carlo Gavazzi

Additional ePowerMeters with RS485 are connected in parallel. The serial output must only be terminated on the last network device connecting terminals B+ and T.

For connections longer than 1000 m or networks with more than 160 instruments, use a signal repeater.

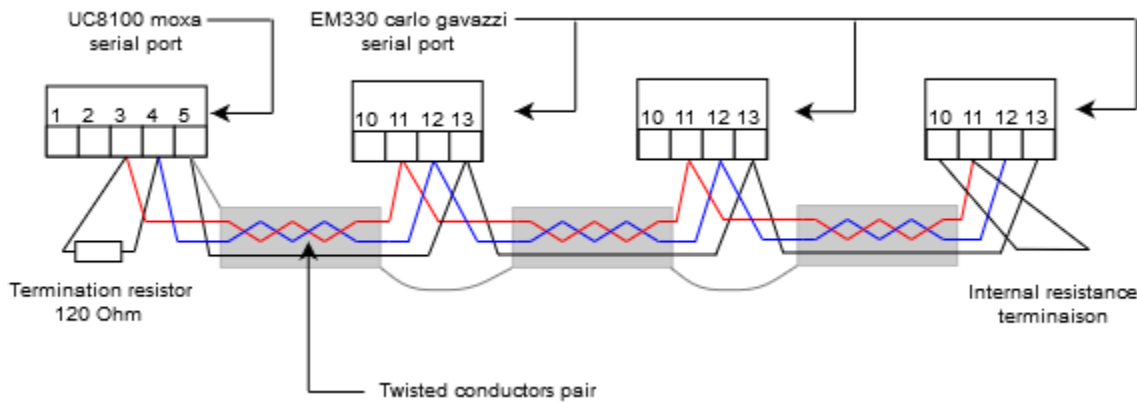

Fig. 13: Connecting several EM330-DIN.AV5.3.H.S1.X, Carlo Gavazzi in parallel



The continuity of the shielding must be ensured throughout the communication cable, and the ground must be connected at a single point. The total length of the cable must not exceed 1200m.

9. Label the newly installed breakers as “ePower Meter Disconnect” so the customer can readily find them if it becomes necessary to power-cycle or turn off the device for any reason.

3.4. Wiring an AC Meter | 333mV provided by Elum

3.4.1. Materials required

The installation and wiring of an AC Meter | 5A provided by Elum requires:

- Per phase: Use of proper smallest available breakers or rated fuse taps for the installation per local NEC rules. Usually 15A circuit breaker or single multipole breaker depending on phases used.
- Black, red, and white stranded AWG 12 wire; length depending on installation location. Thermal resistance to at least 75 C. Blue wire is needed in addition for 3-phase installations. Use wire that has insulation rating greater than the max voltage inside the panel. Note: wire colors may vary based on country and electrical service. Blue wire is needed in addition for 3-phase installations.
- Electrical tape
- Conduit and couplings as needed
- Mounting and wire organization hardware as needed
- If installed outside, appropriately rated enclosure

3.4.2. Safety Warnings



Please follow the installation instructions in this manual for wiring diagram and proper selection of CTs.

To reduce the risk of electric shock:

- Do not connect the device to a circuit operating at > 277 Vrms to neutral.
- Always open or disconnect circuits from Power Distribution System of building before installing or servicing the unit or attached current transformers
- Only connect authorized 333mV CTs to the CT inputs of the device

3.4.3. Installation location

The power meter must be installed near the low voltage distribution where there is easy access to the grid, load and genset connections (see application overview). A 10 A circuit-breaker shall be included (one per phase) in close proximity of the device and within easy reach of the operator. The breakers shall be marked as the disconnecting device for the power meter. The power meter is a listed device and must be installed inside a suitable enclosure. The enclosure the power meter is installed in must be rated according to the environment it is used in. For example, outdoor installations require an outdoor-rated enclosure. Select an installation location that is not exposed to direct sunlight of the elements.

3.4.4. Device overview

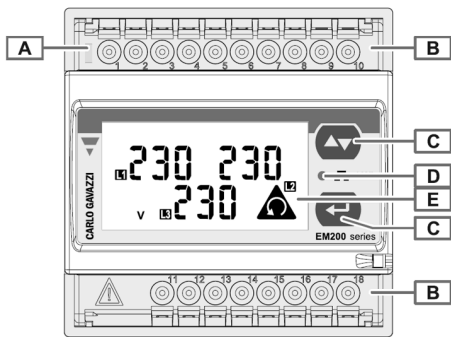

Product

Area	Description
A	Green LED: <ul style="list-style-type: none"> steadily on: instrument powered. blinking: instrument powered and serial communication under way.
B	Terminals for current, voltage and communication connections
C	Control buttons
D	Red LED: <ul style="list-style-type: none"> blinking: pulses proportional to the measured energy (pulse weight: see <i>Features</i>).
E	Non-backlit LCD display

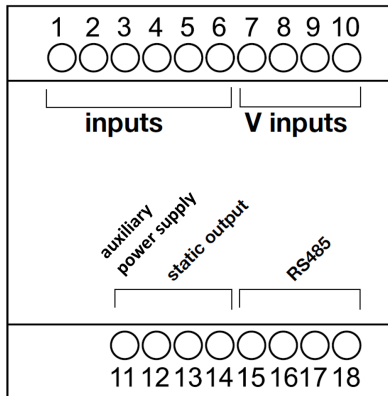

Fig. 14: View of the EM210-72D.MV5.3.X.OS.X, Carlo Gavazzi



Display

Area	Description
A	Measuring unit area
B	Indication area:
	Incorrect phase sequence.
	Displayed line voltages .
	Displayed system values.

Fig. 15: View of the EM210-72D.MV5.3.X.OS.X, Carlo Gavazzi LCD screen

3.4.5. Installation steps

1. Install the breaker(s) in the power-distribution panel so that they provide access to all phases.
2. Open the breakers so there is no power on the breaker contacts.
3. Mount the power meter inside a suitable enclosure near the power distribution panel.

- Proceed to the wiring of the power meter and CTs according to the wiring diagram corresponding to the site system layout. For a three-phase system current, 4-wire, unbalanced load and three current transformers the wiring should be as described below. *Ensure that the stickers on the CTs point towards what is being measured. If it is necessary to shorten or lengthen the CT wires, ensure that the CT wires are properly connected.*



The main voltage must not exceed 400V, and the CTs must always have 333 mV output.

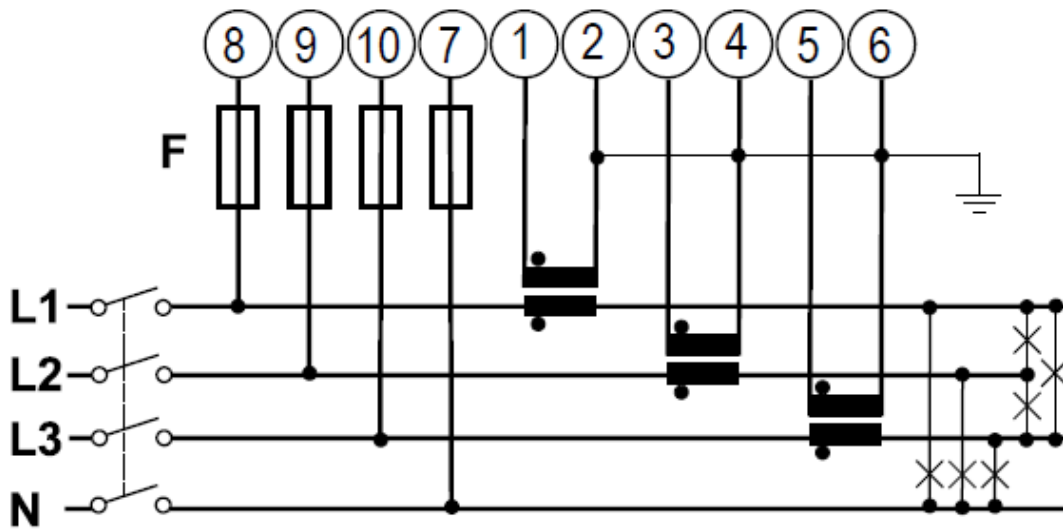

Fig. 16: Example of the EM210-72D.MV5.3.X.OS.X, Carlo Gavazzi connection diagram for a three-phase system of the system, 4 wires, unbalanced load and three current transformers (CT) and three voltage transformers (VT)

- Proceed to the power supply wiring of the power meter as described below.



The power supply should be 65-400 V AC, 50 Hz



The auxiliary power supply on the meter enables it to always be powered up whether the plant is operating on grid or on gensets. Power meters monitoring the grid, the load or gensets should always be powered up. One of those power meters being suddenly turned off would turn the ePowerControl into a fail safe mode, curtailing PV production.

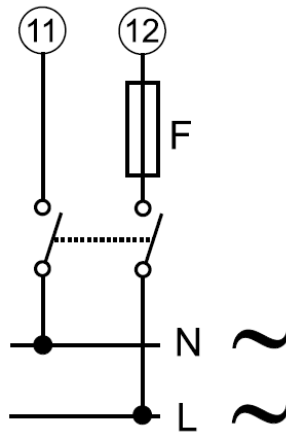

Fig. 17: Connecting the power supply to the EM210-72D.MV5.3.X.OS.X, Carlo Gavazzi

6. Close the newly installed breakers. This should cause the power meter to power up, within a few seconds the screen should light up and display the measurement page.
7. You can now proceed to the parameter setup of the power meter.



When installing a EM210-72D.MV5.3.X.OS.X, Carlo Gavazzi the critical parameters to be set are listed below:

SYS, System type: To be set according to the site design.

SEnSOr , CT type: To be set according to the CTs used with the power meter. As an example, when installing the power meter with Rogowski coil CTs, the type should be set to roG

Ct Prin, Current transformer maximum current input: To be set according to the CTs used with the power meter. As an example, when installing the power meter with Rogowski coil 4000A, the type should be set to 4,00k.

Vt rAtlo, Voltage transformer ratio: To be set according to the VTs used with the ePowerMeter. You can obtain this ratio by dividing the primary voltage by the secondary voltage. As an example, when installing the power meter using no VTs, the ratio should be set to 1.

APPLiC, Measurement application: To be set to "E".

AddrESS, Modbus address: To be set according to your ID plan.



The result of the ratio between the current and voltage transformers must be under 1054.



It is critical that the measurement application was correctly set up to “E” for the zero export control feature. If the ePowerMeter was not correctly set up, Elum cannot guarantee any reliability on the zero export feature and will not be taken responsible if some energy is exported to the grid.



Instructions to use the power meter and navigate through the different menus.

Measurement pages displayed by default when turned on. Pages are characterized by the reference unit of measure. The initial measurement page set is displayed after 120 s of disuse.

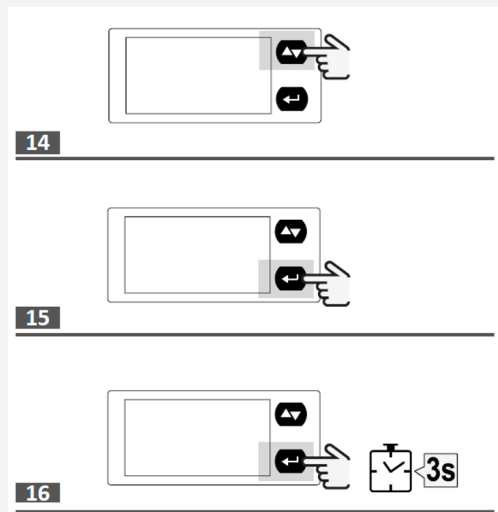

Controls (Fig. 14 – Fig. 16)

Navigation	
Operation	Control
Display the next measurements page	Fig. 14
Open the Information menu	Fig. 15
Display the next information page	Fig. 15
Exit the information menu	Fig. 14
Enter the parameters menu	Fig. 16
Exit the parameters menu (the information menu will be displayed)	Fig. 16 (page End)

Parameter setting

Parameter setting	
Operation	Control
Access the page to set a parameter	Fig. 15
Switch from increase mode (C icon) to decrease mode (-C icon)	Fig. 15
Increase the value of a parameter/display the next option (C icon)	Fig. 14
Decrease the value of a parameter/display the previous option (-C icon)	Fig. 14
Confirm a value	Fig. 16

NOTE: hold it pressed for at least 2.5 s.

- Proceed to the communication wiring of the power meter as described below. Connect the ePowerMeter using a shielded twisted pair RS485 connector to one of the serial ports of the Central Computing Unit using a Cat 5 cable.

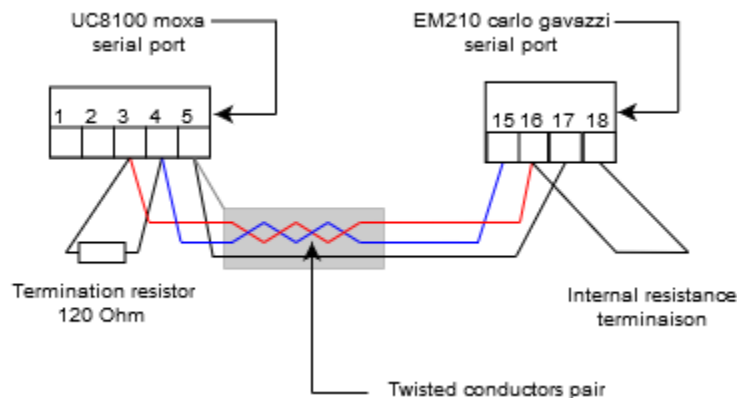

Fig. 18: Connecting a single EM210-72D.MV5.3.X.OS.X, Carlo Gavazzi

Additional ePowerMeters with RS485 are connected in parallel. The serial output must only be terminated on the last network device connecting terminals B+ and T.

For connections longer than 1000 m or networks with more than 160 instruments, use a signal repeater.

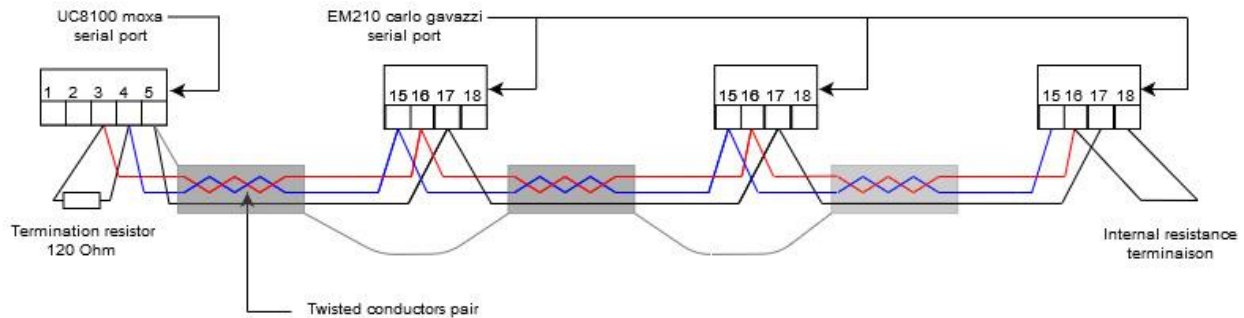

Fig. 19: Connecting several EM210-72D.MV5.3.X.OS.X, Carlo Gavazzi in parallel



The continuity of the shielding must be ensured throughout the communication cable, and the ground must be connected at a single point. The total length of the cable must not exceed 1200m.

Label the newly installed breakers as “ePower Meter Disconnect” so the customer can readily find them if it becomes necessary to power-cycle or turn off the device for any reason.

4. Step 4: Configuring non-Elum equipment

4.1. Configuring Solar Inverters

Some inverters may need the activation of RS485 control features. To configure a given inverter, please refer to the manufacturer's instructions and to the Device Connection & Configuration Specific Instructions provided by Elum.

Elum ePowerControl needs to communicate with solar inverters to control their active power injection, as well as gather data for monitoring purposes.

To perform this task the controller must be able to interact with the solar inverters to:

- Collect active power output measurements,
- Communicate maximum power output setpoints,
- Collect accessible measurements useful for the monitoring of the operation.

In the following table all the accessed variables are listed.

Table 3: Solar inverter variable accessed

Elum Name	Description	Max Access
W	Total active power	Read Only
WphA	Active power phase A	Read Only
WphB	Active power phase B	Read Only
WphC	Active power phase C	Read Only
VAR	Total reactive power	Read Only
VARphA	Reactive power phase A	Read Only
VARphB	Reactive power phase B	Read Only
VARphC	Reactive power phase C	Read Only
VA	Total apparent power	Read Only
VaphA	Apparent power phase A	Read Only
VaphB	Apparent power phase B	Read Only
VaphC	Apparent power phase C	Read Only
Hz	Frequency	Read Only
AphA	Current phase A	Read Only

AphB	Current phase B	Read Only
AphC	Current phase C	Read Only
PhVphA	Line voltage phase A	Read Only
PhVphB	Line voltage phase B	Read Only
PhVphC	Line voltage phase C	Read Only
Status	Solar inverter status	Read Only
Operating Mode	Solar inverter operating modes	Read Only
Alarm	Solar inverter alarms	Read Only
WSet	Solar inverter maximum active power setpoint	Read / Write

Table 4: Requirement for solar inverter

RS1	Each inverter must allow Modbus RTU or TCP communication
RS2	Each inverter must allow active power setpoint communication via Modbus RTU or TCP

4.2. Configuring Genset Controllers

To configure remote communication or activate the reverse power protection on a given genset controller, please refer to the manufacturer's instructions and to the Device Connection & Configuration Specific Instructions provided by Elum.

Elum ePowerControl needs to communicate with the genset itself or with the genset controller to surveil safe operation and to gather data for site monitoring purposes. To perform such task the controller must be able to interact with the genset itself or with the genset controller to collect:

- Active power output measurements
- Accessible data for the monitoring of the operation.

In the following tables all the accessed variables are accessed.

Table 5: Genset or genset controller variable accessed

Elum Name	Description	Max Access
W	Total active power	Read Only
WphA	Active power phase A	Read Only

WphB	Active power phase B	Read Only
WphC	Active power phase C	Read Only
VAR	Total reactive power	Read Only
VARphA	Reactive power phase A	Read Only
VARphB	Reactive power phase B	Read Only
VARphC	Reactive power phase C	Read Only
VA	Total apparent power	Read Only
VaphA	Apparent power phase A	Read Only
VaphB	Apparent power phase B	Read Only
VaphC	Apparent power phase C	Read Only
Hz	Frequency	Read Only
AphA	Current phase A	Read Only
AphB	Current phase B	Read Only
AphC	Current phase C	Read Only
PhVphA	Line voltage phase A	Read Only
PhVphB	Line voltage phase B	Read Only
PhVphC	Line voltage phase C	Read Only
Status	Genset status	Read Only
Operating Mode	Genset operating modes	Read Only
Alarm	Genset alarms	Read Only

Table 6: Requirement for genset or genset controller

RS1	The genset or the controller must allow Modbus RTU or TCP communication
------------	---

4.3. Configuring Grid and Load Sensors

Elum ePowerControl needs to obtain information from the Point of Connection (POC) between the site and the external power grid, and from the Load. Such information is obtained by installing a sensor able to measure all the electrical quantities needed.

Elum ePowerControl needs to communicate with the sensor installed to collect:

- Active power measurements
- Accessible data for the monitoring of the operation.

The power meters provided by Elum meet all those conditions and will be used by default.

To configure remote communication on a given power meter, please refer to the manufacturer's instructions and to the Device Connection & Configuration Specific Instructions provided by Elum.

In the following tables all the accessed variables are listed.

Table 7: Grid sensor variable accessed

Elum Name	Description	Max Access
W	Total active power	Read Only
WphA	Active power phase A	Read Only
WphB	Active power phase B	Read Only
WphC	Active power phase C	Read Only
VAR	Total reactive power	Read Only
VARphA	Reactive power phase A	Read Only
VARphB	Reactive power phase B	Read Only
VARphC	Reactive power phase C	Read Only
VA	Total apparent power	Read Only
VaphA	Apparent power phase A	Read Only
VaphB	Apparent power phase B	Read Only
VaphC	Apparent power phase C	Read Only
Hz	Frequency	Read Only
AphA	Current phase A	Read Only

AphB	Current phase B	Read Only
AphC	Current phase C	Read Only
PhVphA	Line voltage phase A	Read Only
PhVphB	Line voltage phase B	Read Only
PhVphC	Line voltage phase C	Read Only

Table 8: Requirement for grid sensor

RS1	The sensor must allow Modbus RTU or TCP communication
------------	---

5. Step 5: Installing the ePowerControl

5.1. Installation

**Installation location**

The ePowerControl enclosure is designed for indoor installations. For outdoor installations, special housing must be provided when placing the order.

**Internet access**

The autonomous deployment of ePowerControl as well as any maintenance intervention by Elum engineers requires a stable connection to the Internet. The enclosure must be installed in such a way that it has a reception quality at least at Edge level for wireless connection, or at least an equivalent quality on the local network for wired connection. (Cf. [Appendix C: Internet Speed Test](#))

5.1.1. Instructions the ePowerControl is delivered in a casing

The manufacturer's enclosure plan can be provided by Elum upon request. To wall-mount the ePowerControl enclosure follow these steps:

1. Facilitate the access to the mounting holes by removing the 4 nuts fixing the mounting plate to the enclosure
2. Mount the Base station to the wall using appropriate screws and wall plugs
3. Set back the mounting plate into the enclosure

5.1.2. Instructions the ePowerControl is delivered as a kit

When delivered as a kit, the ePowerControl components should all be installed on a DIN rail. To avoid the Central Computing Unit overheating, respect a 15 cm cooling area on each side of it.

5.2. Power Supply

To power the electrical enclosure, use the screw terminal block. Allowed voltage ranges from 100 to 240 Volts AC, and the device may use 1.30 A maximum.

**Power source**

Power source supplying the controller must be taken from the load side so that the controller is power supplied both when operating on "On grid - Grid connected mode" and on "Off grid - Genset connected mode". If an UPS is used, the power source of the UPS must follow the same rule.



UPS

For ePowerControl SD, HFS and MC, the use of an UPS is mandatory.

5.2.1. Instructions for connecting the power supply to ePowerControl when in Elum casing

1. Power connectors have already been wired to a single screw terminal block on the left side of the DIN Rail

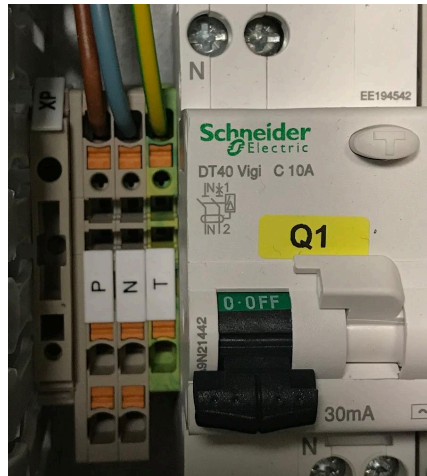

Fig. 20: Terminal block and circuit breaker overview

2. Connect the phase wire to the red/brown wire
3. Connect the neutral wire to the blue wire
4. Connect the ground wire to the green/yellow wire
5. If a UPS was provided with the ePowerControl, connect the battery red/black wire to the transformer
6. Engage the circuit breaker
7. Check that the Power LED of the Central Computing Unit is on.

5.2.2. Instructions for connecting the power supply to ePowerControl when in kit

Table 9: ePowerControl Power Supply Parameters

Input voltage	12 to 24 VDC
Input Current	480 mA @ 12 VDC 225 mA @24 VDC
Power Consumption	5,4 W

1. Connect the “terminal block to power jack converter” (in the package) to the Central Computing Unit DC terminal block (located on the top panel), and then connect the power adapter. It takes about 30 seconds for the system to boot up. Grounding the Central Computing Unit Grounding and wire routing helps limit the effects of noise due to electromagnetic interference (EMI).

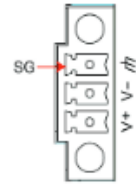

2. Ground the Central Computing Unit. The shielded ground (sometimes called protected ground) contact is the top contact of the 3-pin power terminal block connector when viewed from the angle shown here. Connect the shielded ground wire to an appropriate grounded metal surface.



When the ePowerControl from Elum is turned on, all LEDs should be turned on for 1 sec then off for 60 seconds, (Internet connection and services starting)

Front View

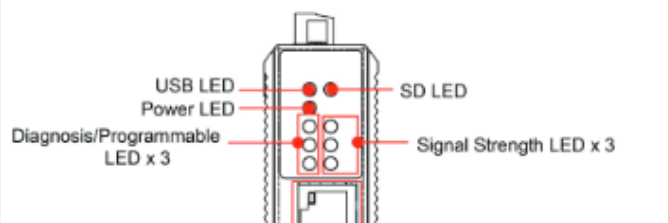

On the left side, LEDs for diagnosis:

- Green light (independant from orange and red lights): When this LED is ON, the local data retrieval system is functioning. If this LED is OFF, the retrieval system and/or the local database are inactive.
- Orange light ON, with red light OFF: connection to Elum server is active
- Red light ON, with orange light OFF: connection to Elum server is inactive
- Red light BLINKING: The local data retrieval system is inactive and the connection to the Elum server is not active.

On the right side, LEDs for network:

- Red light BLINKING: No internet connection
- Green light ON, other lights OFF: Internet access via Ethernet OK
- Red light ON, other lights OFF: Internet access via 3G,4G,GSM / Quality reception < 25 %
- Red and orange lights ON, green OFF: Internet access via 3G, 4G, GSM / Quality reception between 25 % and 50%
- Red, orange and green ON: Internet access via 3G,4G,GSM / Quality reception > 50%

6. Step 6: Configuring the ePowerControl on Elum Configuration

6.1. Before proceeding to the commissioning

6.1.1. Required Materials

To perform the configuration of the internet access you will need the following items:

- A computer with an ethernet port
- An ethernet cable

6.1.2. Prerequisite

Before proceeding to the commissioning of your system, Elum can ask you to proceed to an update of the firmware so that you can have access to the latest version of Elum Configuration with the latest communication drivers version. It is key that you have up to date drivers so that the communication tests you will proceed with are reliable and you can be autonomous for the wiring review and configuration of the ePowerControl.

6.2. Accessing Elum Configuration

1. Connect your laptop to the port LAN2 of the Central Computing unit.

For next steps, the Central Computing Unit must be powered on (refer to the power led)

2. Open your favorite web browser and enter **192.168.4.127** in the URL bar



To access the Elum Configuration local web page, the Ethernet port of your computer should be configured in DHCP mode.

6.3. Configuring your password

In the login page, please start by setting an access password, this password will give access to Elum Configuration menus and will be asked every time you connect to the ePowerControl and try to access the Settings tab. Then click on “Continue”.

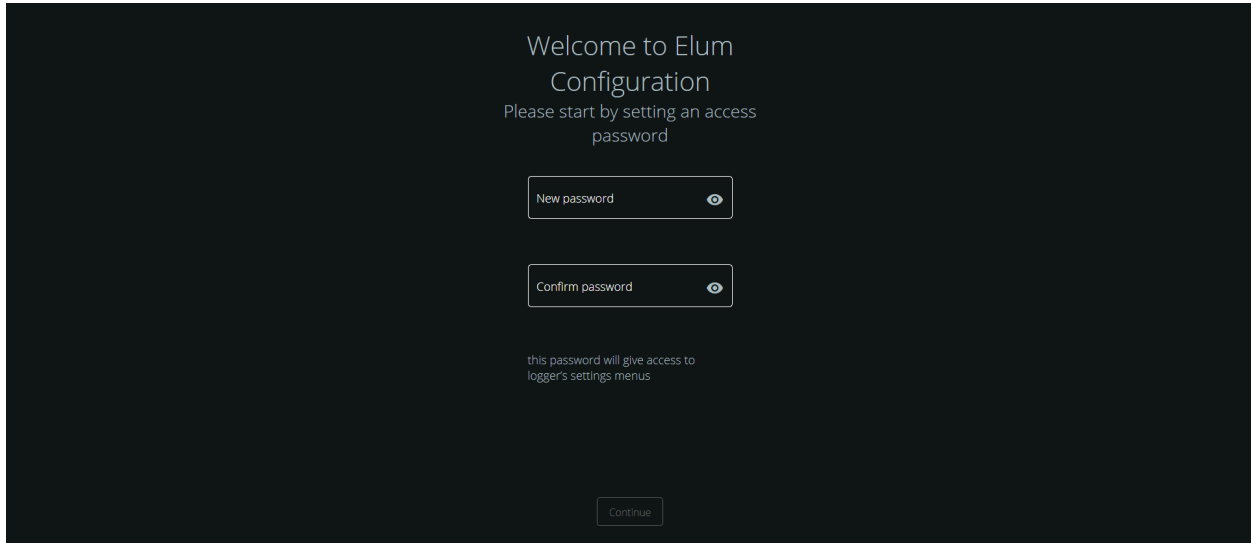

Welcome to Elum
Configuration
Please start by setting an access
password

New password

Confirm password

this password will give access to
logger's settings menus

Continue

Fig. 21: Elum Configuration Password panel

6.4. Configuring site settings (optional)

Indicate the name and the GPS coordinates of the site associated with the Elum controller.



The information provided in this panel will be used for the configuration of the ePowerMonitor dashboard. Accessing the ePowerMonitor requires the subscription to the ePowerMonitor platform.

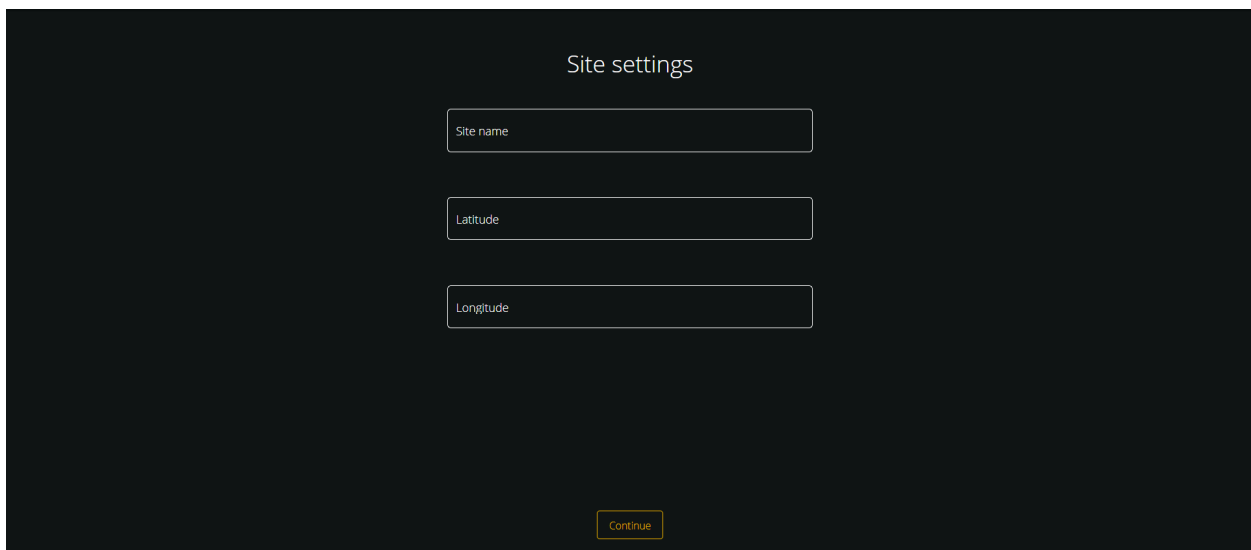

Site settings

Site name

Latitude

Longitude

Continue

Fig. 22: Elum Configuration Site panel

6.5. Configuring data forwarding (optional)

Elum energy offers an optional data export function that allows the export of data to one or more third party platforms or to USB devices. If you do not intend to export data to a third party platform other than ePowerMonitor or to USB Device, please skip to the next configuration section, by clicking on “Skip”.

Three export possibilities are available:

- FTP Push to Energysoft monitoring platform with S4E PowerAPI data format;
- FTP Push to any other third party party internal or external server supporting FTP protocol with Elum Energy data format;
- Push to an USB device



To request further information about Elum Data export feature and especially data format, contact Elum at support@elum-energy.com.



If needed, all export methods can operate simultaneously.

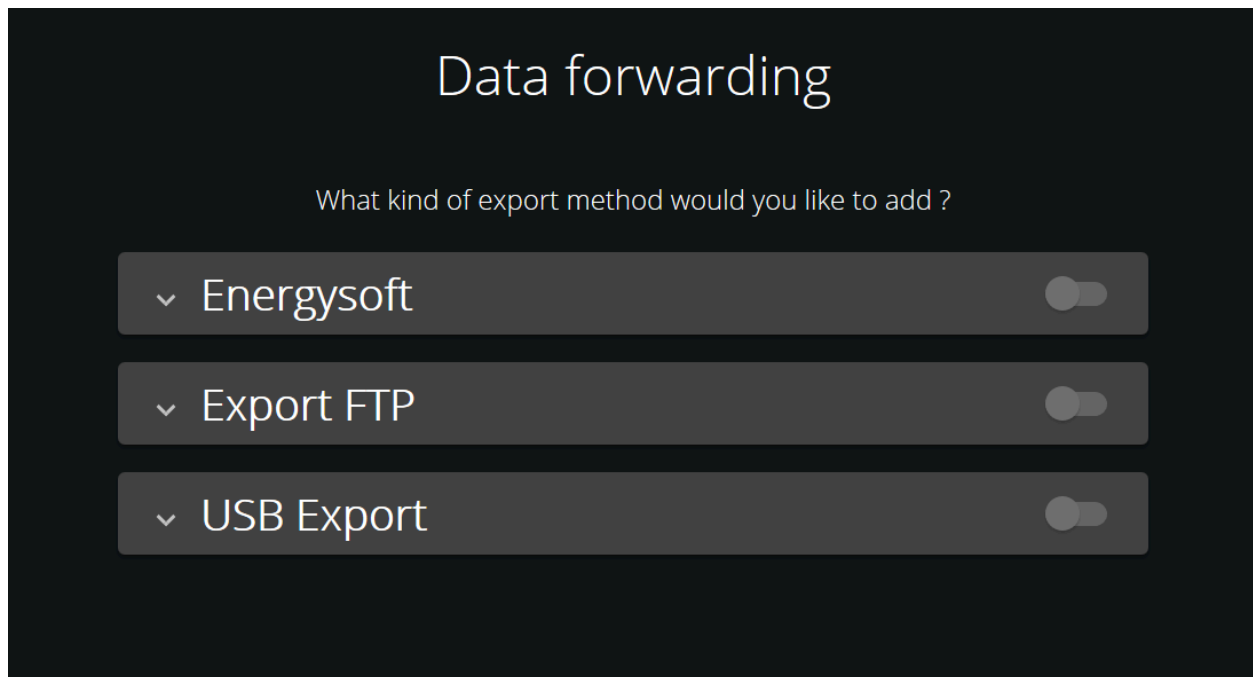
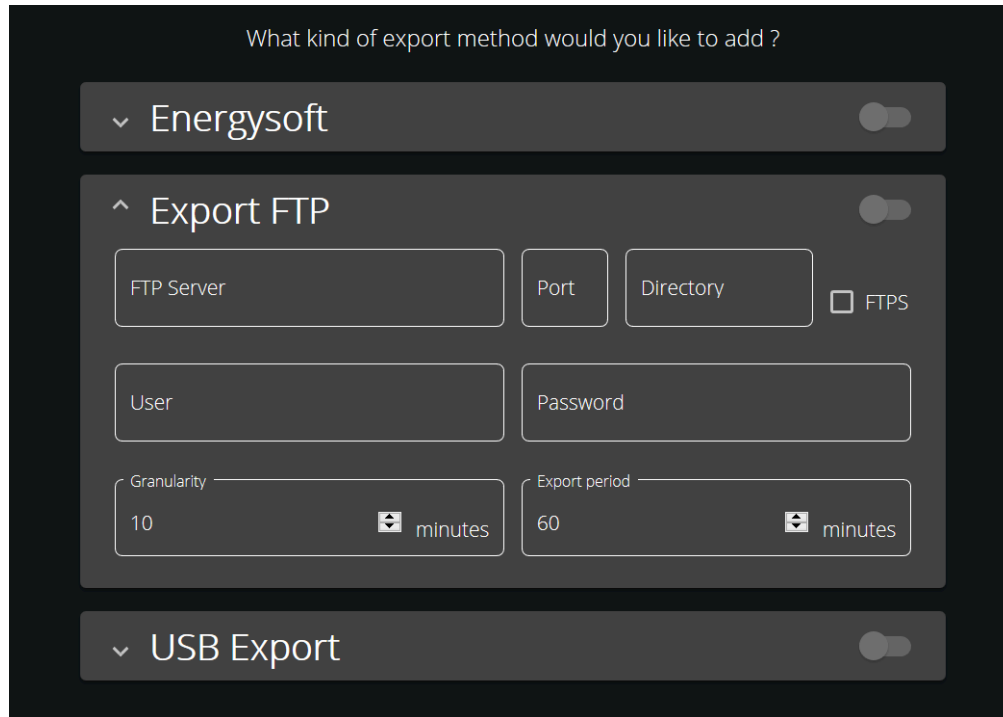

Fig 23: Data forwarding configuration panel

Start by choosing an export method, you will then be asked some further details to set up the data forwarding.

6.5.1. Export FTP



What kind of export method would you like to add ?

Energysoft

Export FTP

FTP Server Port Directory FTPS

User Password

Granularity 10 minutes Export period 60 minutes

USB Export

Fig. 24: FTP export configuration

Inform the FTP server, port and directory, you want to forward your data to.

Add your User and Password credentials to access the FTP Server indicated above.

Indicate the granularity of the data forwarded to your FTP server.

The export period can also be edited independently from the granularity.

6.5.2. Energysoft

Energysoft is also based on FTP protocol but with only a different export file format than Elum standard FTP push service, thus, the same forwarding settings are applicable for both export methods.

For further information see previous section [Export FTP](#).

6.5.3. USB Export

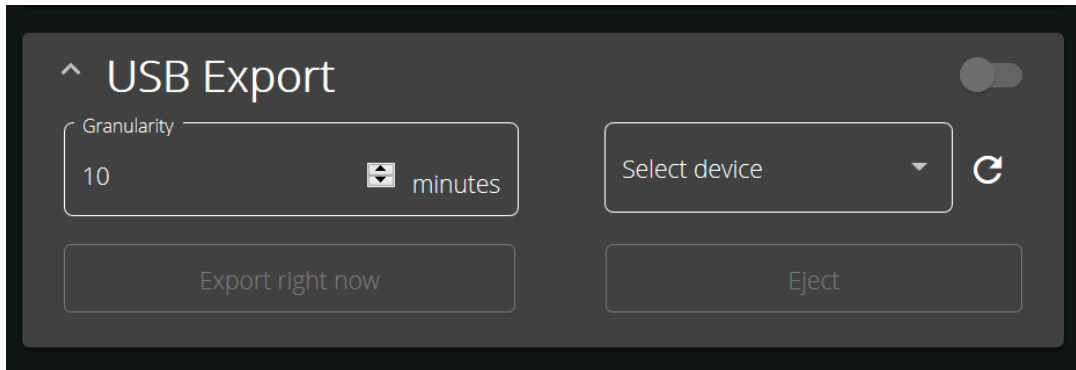

Fig. 25: USB export configuration

When an USB device is plugged, it will appear in the device selection list of the USB export configuration panel. Select the USB device you want to forward your data to.

Indicate the granularity of the data forwarded to your USB device.

The export period is independent of the granularity, and is of 24h, every export happening at 00:00 UTC everyday.

By clicking on “Export right now”, the data of the current export period will be exported to the USB device. You can click on “Export right now” anytime, especially it is highly recommended to use it just before ejecting your USB device. Your USB device can be ejected anytime, by clicking on “Eject”.



To avoid any damage on your USB device, you must always eject it before removing it from the Elum Explorer USB port. Not ejecting your device can also cause irreversible data loss.

6.6. Configuring internet access

After having chosen and set your password you should arrive in the Network Panel.

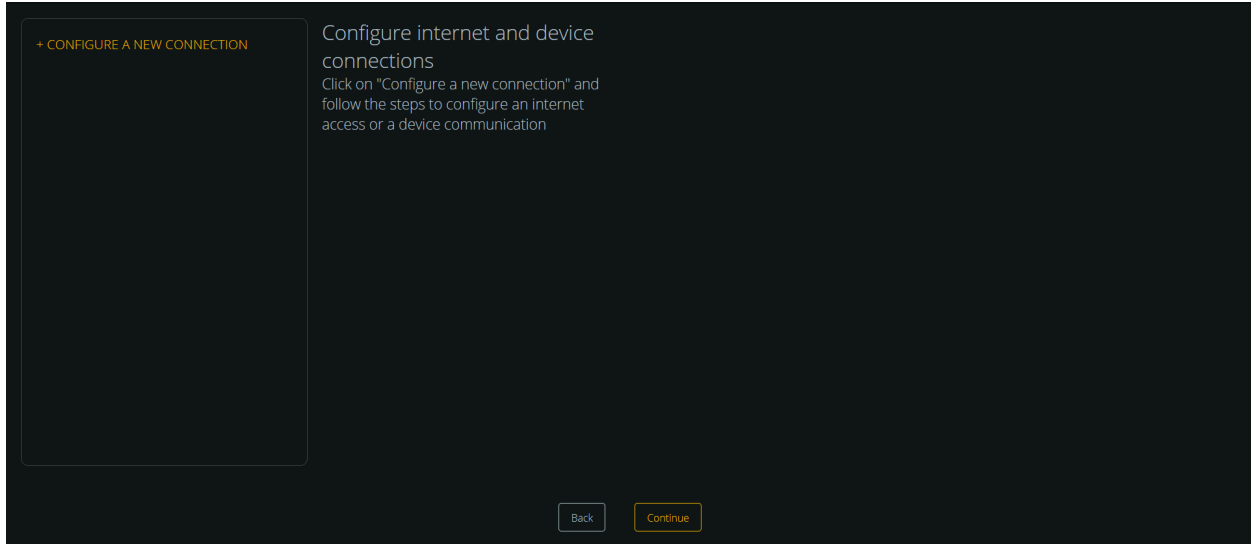

Fig. 26: Elum Configuration Network panel

6.6.1. Configuring a wired internet connection



The LAN connection enabling the ePowerControl to access the internet through a wired connection, should always be done through the LAN port 1 of the Central Computing Unit. A switch can be connected to LAN port 1 if more LAN ports are needed.



For this step we will need the full cooperation of the IT team to configure the internet network. Here are the things you should ask him:

To be able to join our back end, the controller must have these ipv4 outgoing accesses:

- ICMP
- TCP ports: 53, 80, 443, 4505, 4506
- UDP ports: 53, 123, 1195

Please provide the network configuration to be applied on our equipment before installation

No optional module is needed to establish a wired internet connection between the ePowerControl and the internet.

1. Start by clicking on “+ Configure a new connection” and select “Internet access” then “Wired Access - lan1”.

Connection settings

Connection type
Internet access

Interface
Wired Access - lan1

mode
DHCP

ip
172.18.128.232

mask
255.255.255.0

gateway
172.18.128.1

name_servers +

8.8.8.8 ×
8.8.4.4 ×

Cancel Ok

Fig. 27: Internet access through wired access configuration

2. Then enter appropriate connexion parameters for your network and press OK.

3. Test the connexion with the test button .

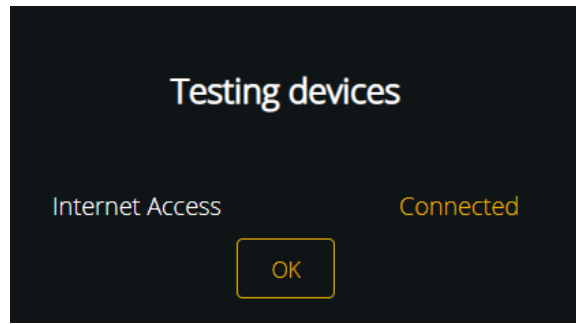

Fig. 28: Internet access through wired access testing

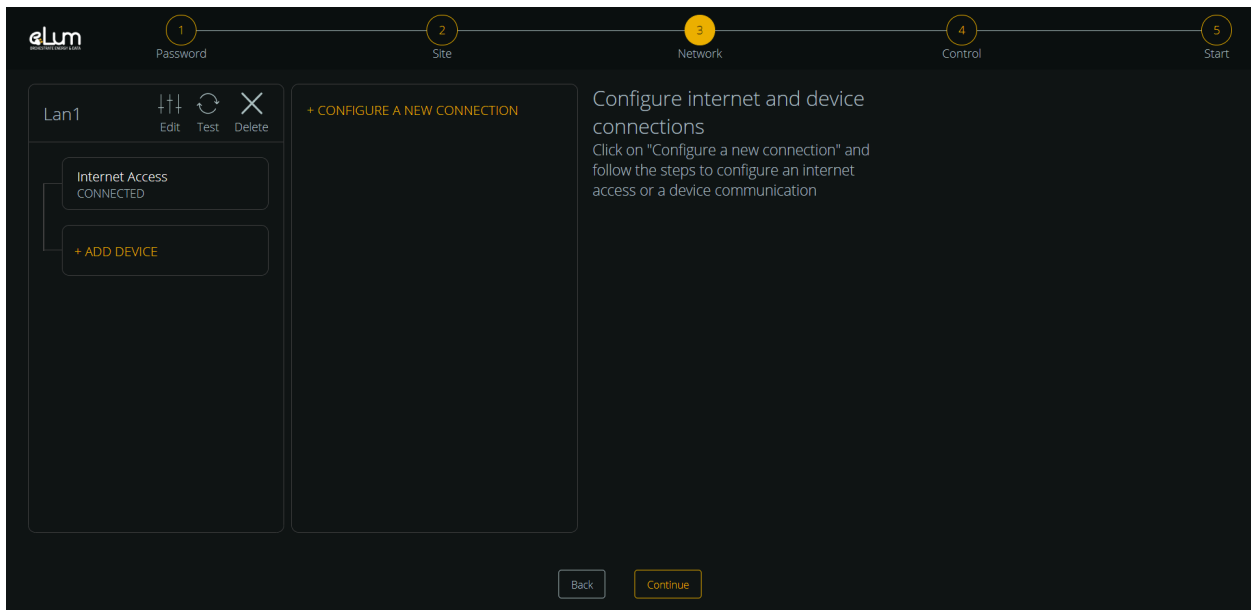

Fig. 29: Internet access through wired access status

6.6.2. Configuring a cellular internet connection



The GSM/3G kit is pre-embedded in the Central Computing Unit. You also need a SIM card with a subscription to a valid “data” contract.



ePowerControl must be turned off each time a SIM card is inserted or removed from the SIM card slot. In addition, if for any reason it is necessary to change the SIM card for another one, it will be necessary to perform an empty start of the ePowerControl.

For these steps, the Central Computing Unit must NOT be powered on.

- 1.** Connect the two wireless antennas to the dedicated connectors



The antenna connectors are located on the front panel of the Central Computing Unit



2. Insert the SIM card in the SIM card slot



The SIM card slot is located next to the two ports W1 and W2 for antennas. It is necessary to open the cover with a screwdriver. You can then insert the SIM card directly into the socket. You will hear a "click" when the card is fixed in place.



3. You can now power ON the Central Computing Unit



When the Central Unit is started, all the diodes are ON for 1 second and then all OFF for 60 seconds, the time required to start the services.

4. Wait for approximately 1 minute
5. In the Network Panel start by clicking on "+ Configure a new connection" and select "Internet access" then "3G Access - builtin"

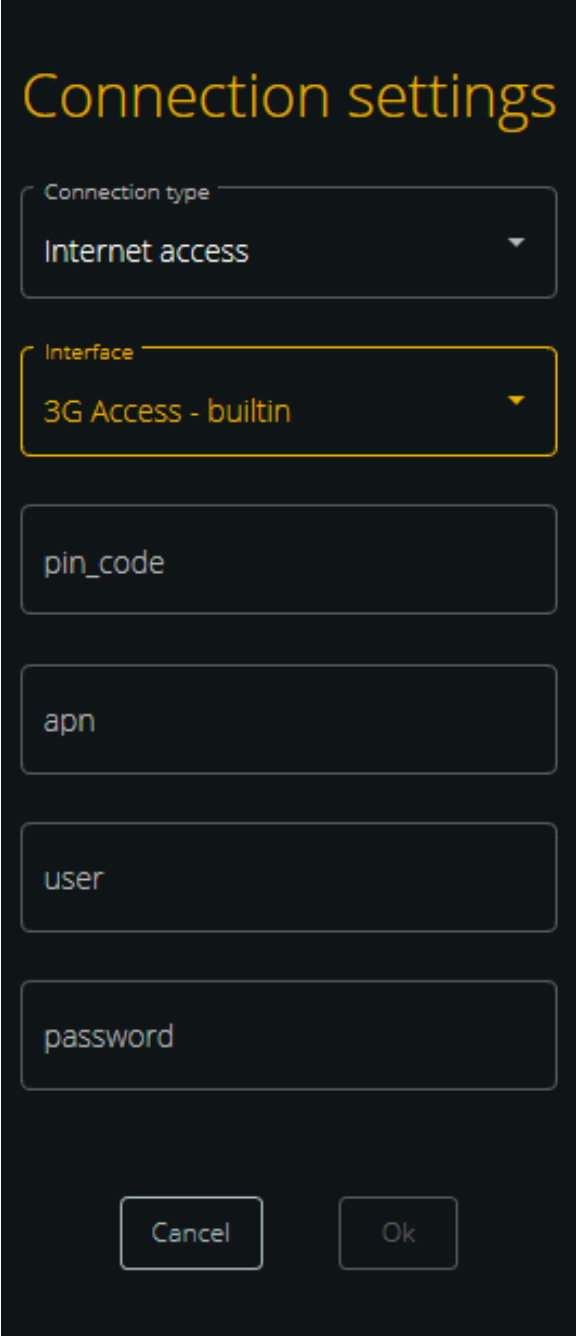

Connection settings

Connection type
Internet access

Interface
3G Access - builtin

pin_code

apn

user

password

Cancel Ok

Fig. 30: Internet access through 3G access configuration

6. Then enter appropriate connexion parameters for your network. Press OK.

7. Test the connexion with the test button .

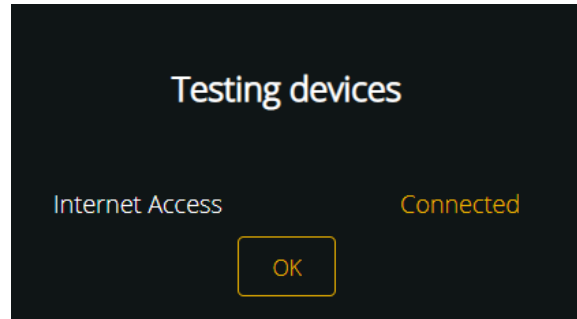

Fig. 31: Internet access through 3G access testing

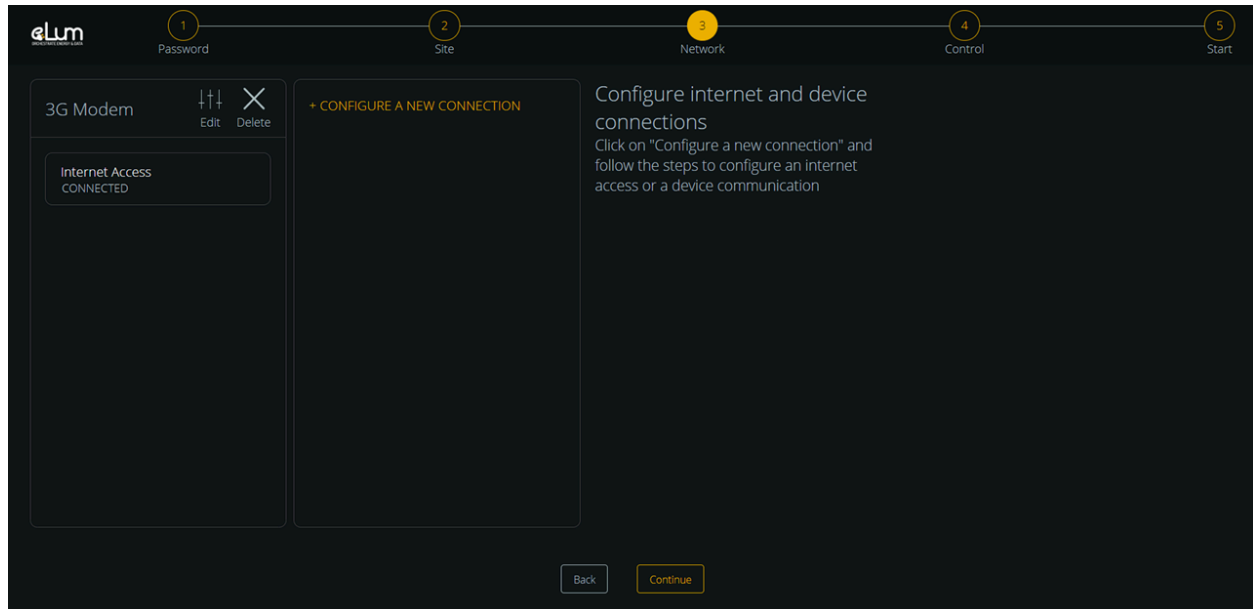

Fig. 32: Internet access through 3G access status



To get your SIM card PIN number, the APN address and the appropriate ids, please refer to your service provider's documentation.

6.7. Configuring ports and devices

Once the wiring and internet configuration has been performed. You can move on to the communication setup with devices.

From Elum Configuration you have to configure each connection corresponding to each of the ports of the Central Computing Unit which are used.

1. Start by clicking on “+ Configure a new connection” and select “Device communication” then the corresponding interface.

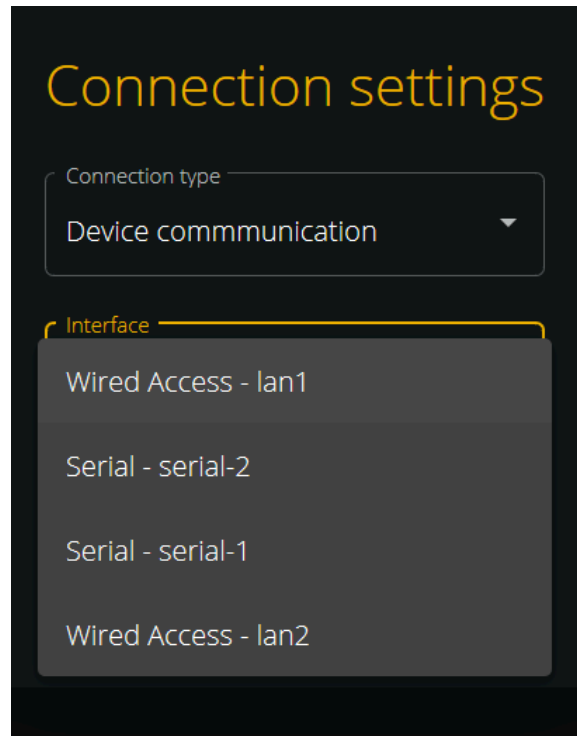

Fig. 33: Connection settings when adding a new port(1/2)



Only the interface which has not been configured yet will be available in the drop-down list. If you want to edit the configuration of a port you already

configured you can edit it directly by clicking on  .

2. Then you have to apply the correct connection settings

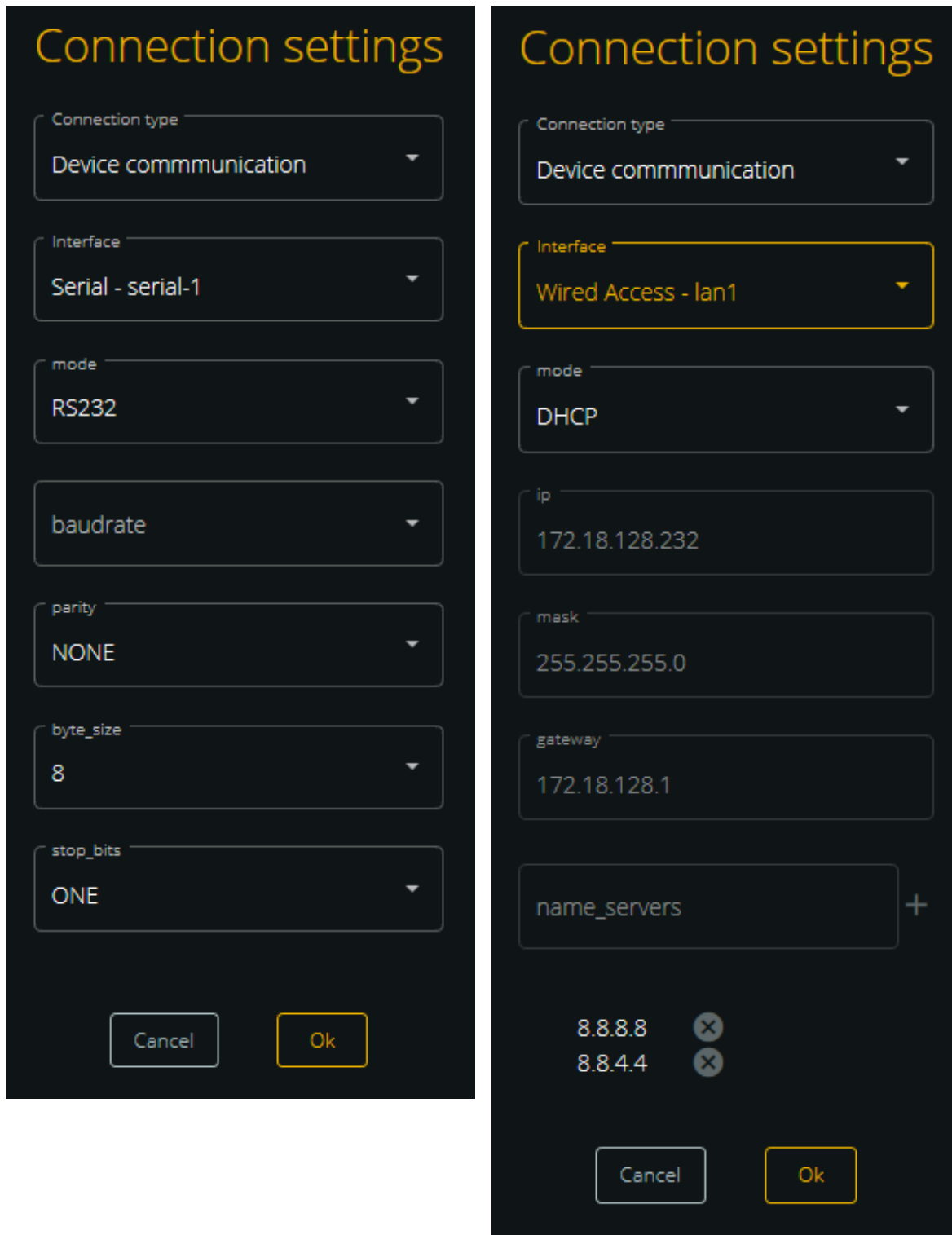

Fig. 34: Connection settings when adding a new port (2/2)

3. Then you have to add each device one by one on each connection port by clicking on “+ add device” and then applying the correct parameters.

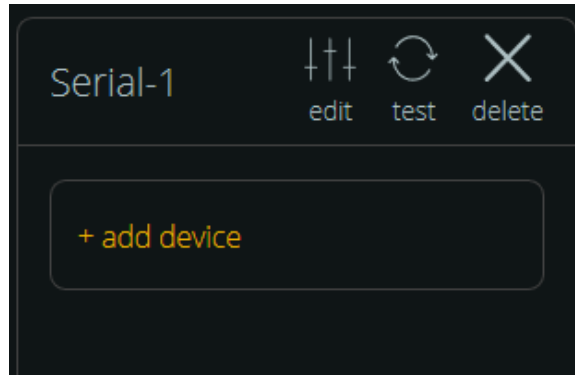

Fig. 35: Associating a device to a communication port (1/2)

A dark-themed dialog box titled 'Add device on serial-1' in orange text. It contains four input fields: a text box for 'Device name', and three dropdown menus for 'Vendor', 'Reference', and 'Protocol'. At the bottom of the dialog are two buttons: 'Cancel' and 'Ok'.

Fig. 36: Associating a device to a communication port (2/2)



Communication parameters

Modbus RTU:

- Slave_id
- Response_timeout (0.5s by default), this is maximum waiting time before receiving the first byte (i.e. before the start of transmission of the response).
- Byte_timeout (0.1s by default), this is the maximum waiting time between subsequent bytes.

Modbus TCP:

- IP
- Port (502 by default)
- Slave_id
- Response_timeout (0.5s by default), this is maximum waiting time before receiving the first byte (i.e. before the start of transmission of the response).
- Byte_timeout (0.1s by default), this is the maximum waiting time between subsequent bytes.

SNMP:

- IP
- Community
- Port (161 by default)
- Transport (UDP by default)
- Timeout (0.5s by default), this is the maximum waiting time before receiving an answer.

4. Test the connection with the device, by clicking either on “Test” to test the communication with all the equipment related to a connection port of the Central Computing Unit.

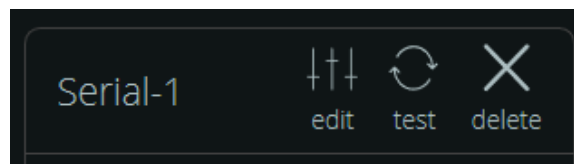

Fig. 37: Testing the connection with all the devices associated to a communication port

Either you can test each device independently by clicking on  next to the name of the device and then “Test connection”.



Fig. 38: Testing the connection with a specific device (1/2)

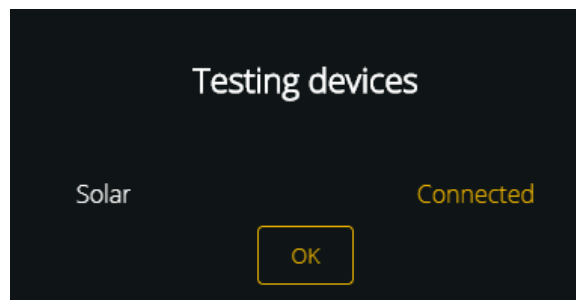

Fig. 39: Testing the connection with a specific device (2/2)

When you proceed to a connection test from the Elum Configuration interface, the ePowerControl will send a read (and depending on the device type, write) request to the equipment. If the test is successful, the device will be described as “Connected”, if not it will be described as “Disconnected”.



Driver error

When you proceed to a connection test, if “Driver error” is returned, it means the device is “Connected” but the driver needs to be updated remotely by Elum. If so, please notify the Elum Deployment Team.

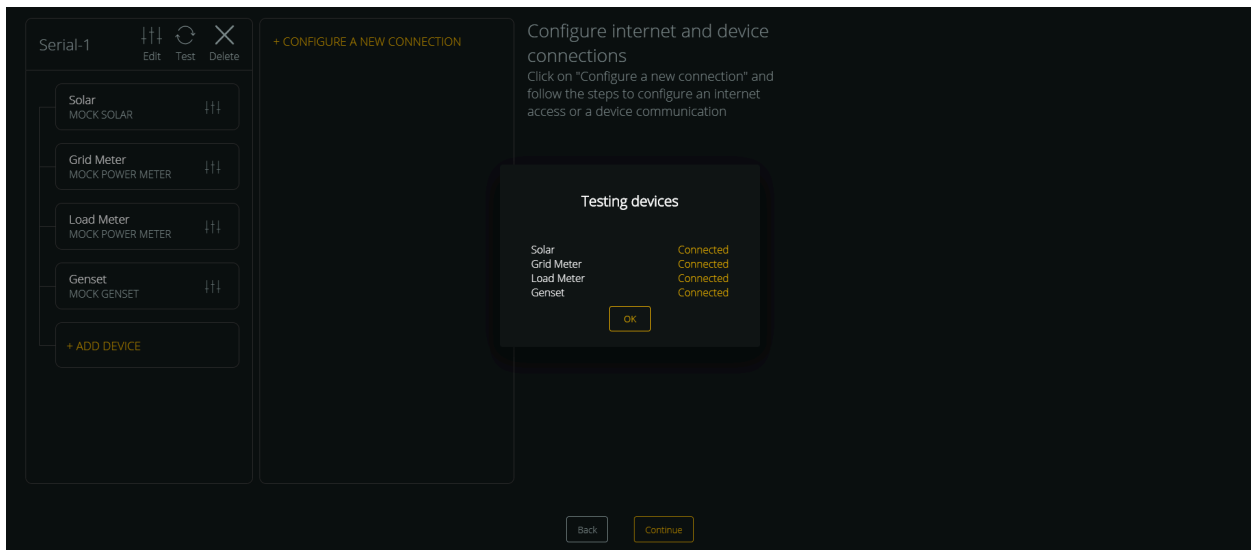

Fig. 40: Testing devices

- Once you have correctly set up all the ports and devices and that all connection tests were successful, you can click on “Continue”.

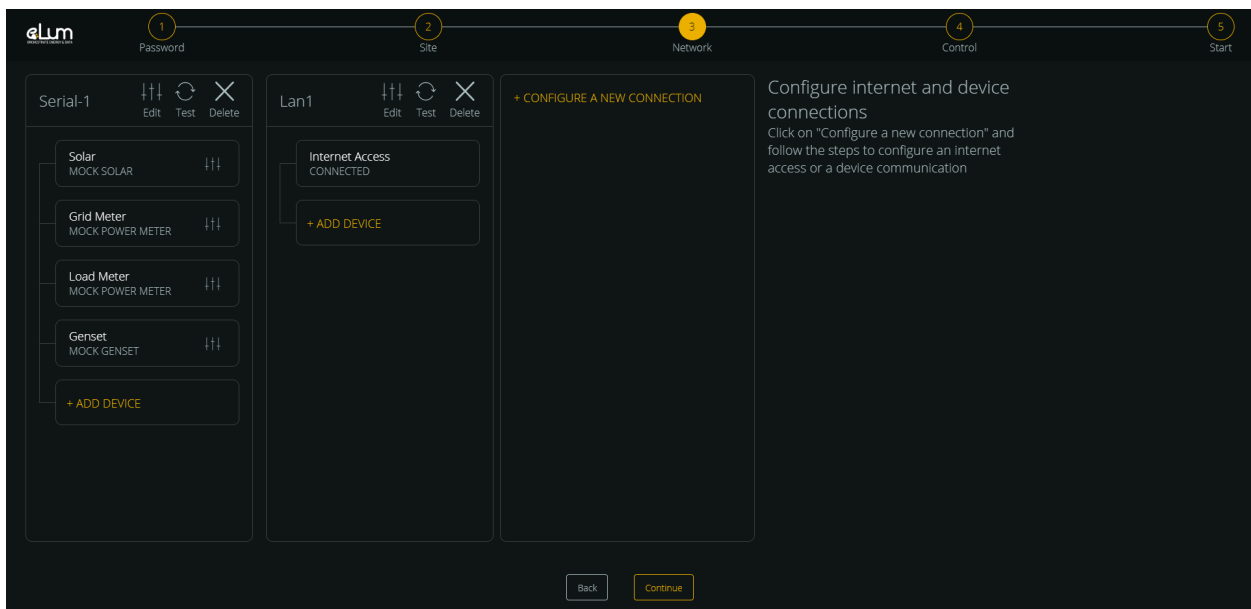

Fig. 41: Network panel



You should only start the data acquisition once you have established a functional communication with all the necessary and useful equipment on site. Elum cannot be taken responsible for the malfunction of the monitoring and control if some equipment is still diagnosed as “Disconnected” by Elum Configuration after you commission your system.

6.8. Configuring your EMS

1. Select the EMS application from the drop-down menu

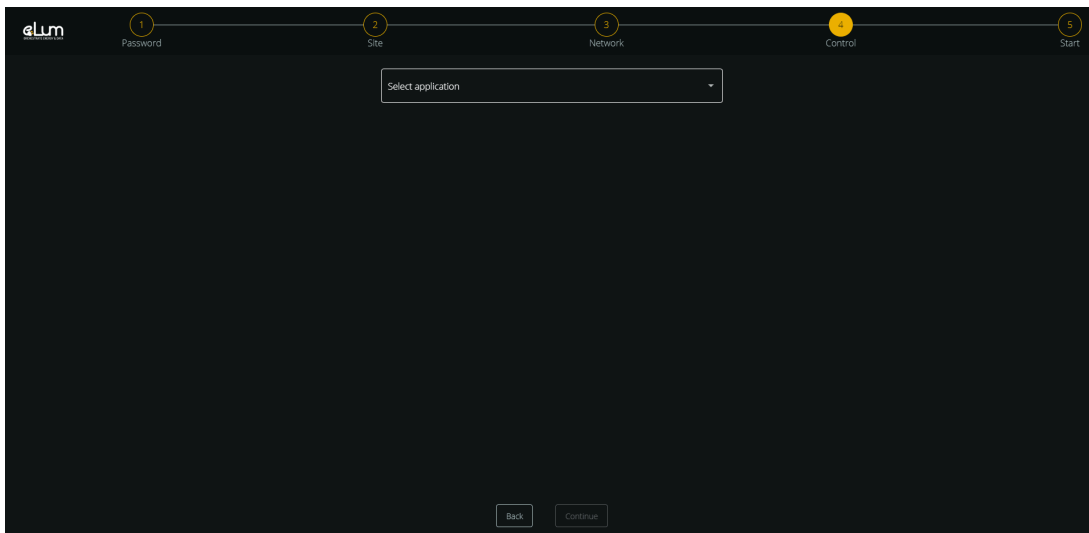

Fig. 42: Control panel, EMS application selection (1/2)

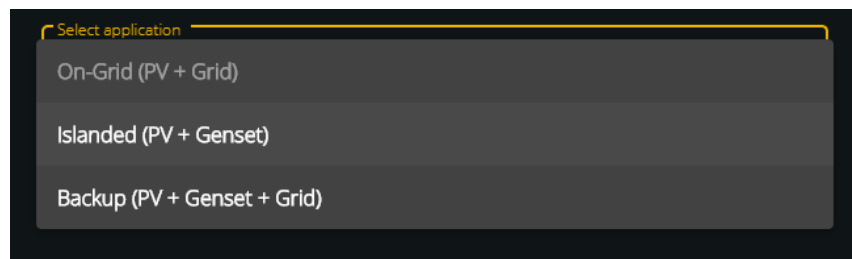



Fig. 43: Control panel, EMS application selection (2/2)

2. Identity Load and/or Grid power meters



The screenshot shows a control panel with three dropdown menus. The first menu is labeled 'Application' and has 'Backup (PV + Genset + Grid)' selected. The second menu is labeled 'Grid meter' and is currently blank. The third menu is labeled 'Load meter' and is also currently blank.

Fig. 44: Control panel, Power meters identification



Load meter

The load power meter can be useful for the installer to proceed to some consistency check up. However it is not a mandatory component to allow a correct functioning of the ePowerControl.

As a matter of fact, you can leave the Load meter field blank.

Nevertheless, if a load indicator is identified from the control panel, it will be taken into account by the EMS in the control loop as a critical device and considered for triggering the safety mode.

3. Configure minimum genset loading setpoint (for Islanded and Backup applications only)
4. List gensets and indicate their nominal power (for Islanded and Backup applications only)



The screenshot shows a 'Genset list' configuration screen. It features a 'Minimum loading' input field with the value '0' and a '%' unit. Below it is a 'Select genset measurement' dropdown menu. To the right, there is a 'Nominal power' input field with the value '0' and a 'kW' unit, accompanied by a '-' button. At the bottom left, there is a '+' button.

Fig. 45: Control panel, Genset identification and minimum genset loading setup

5. You can click on "Continue" when you finished indicating all the relevant power source data

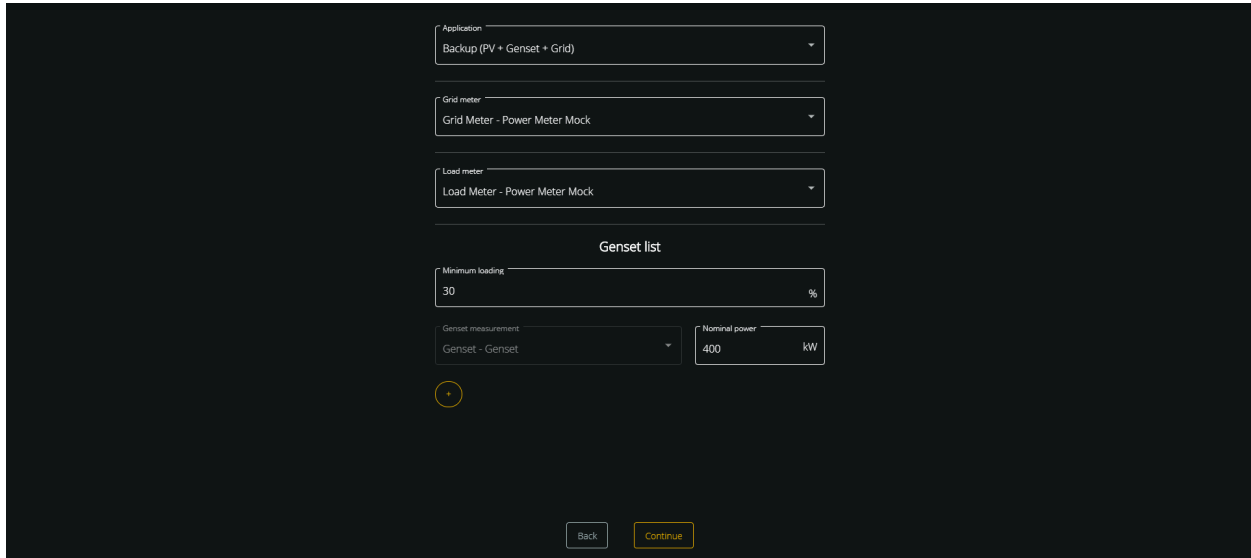

Fig. 46: Control panel, review

6.9. Starting data acquisition and EMS

1. Confirm that you want to start the data acquisition by clicking on “Start”. When starting the data acquisition the EMS control is also automatically started.

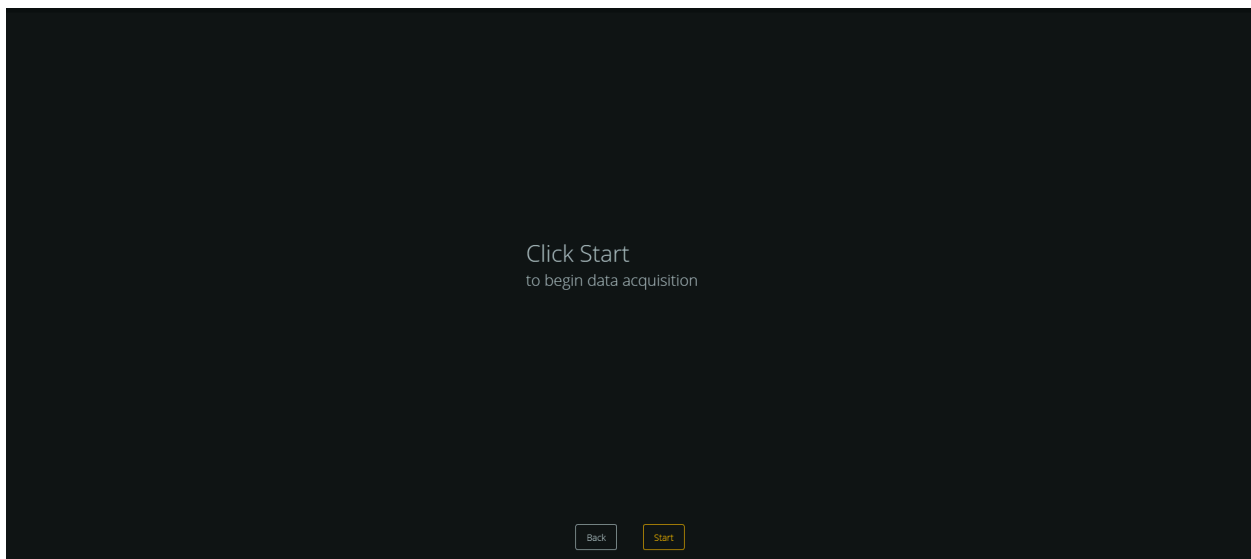

Fig. 47: Start Acquisition panel of Elum Configuration

2. Once data acquisition has been started you can have an overview of the monitored equipment from the Overview panel (and Devices panel). On the upper part of the Overview panel you can see the status of the control. When you just launched the EMS it should appear as “PV ramping ON”. After a short time it will change to “PV ON”. After the commissioning you can still access the Settings tab.



Your password will be required when trying to access to the Settings tab



Please notice that some settings can only be changed after turning the EMS off.

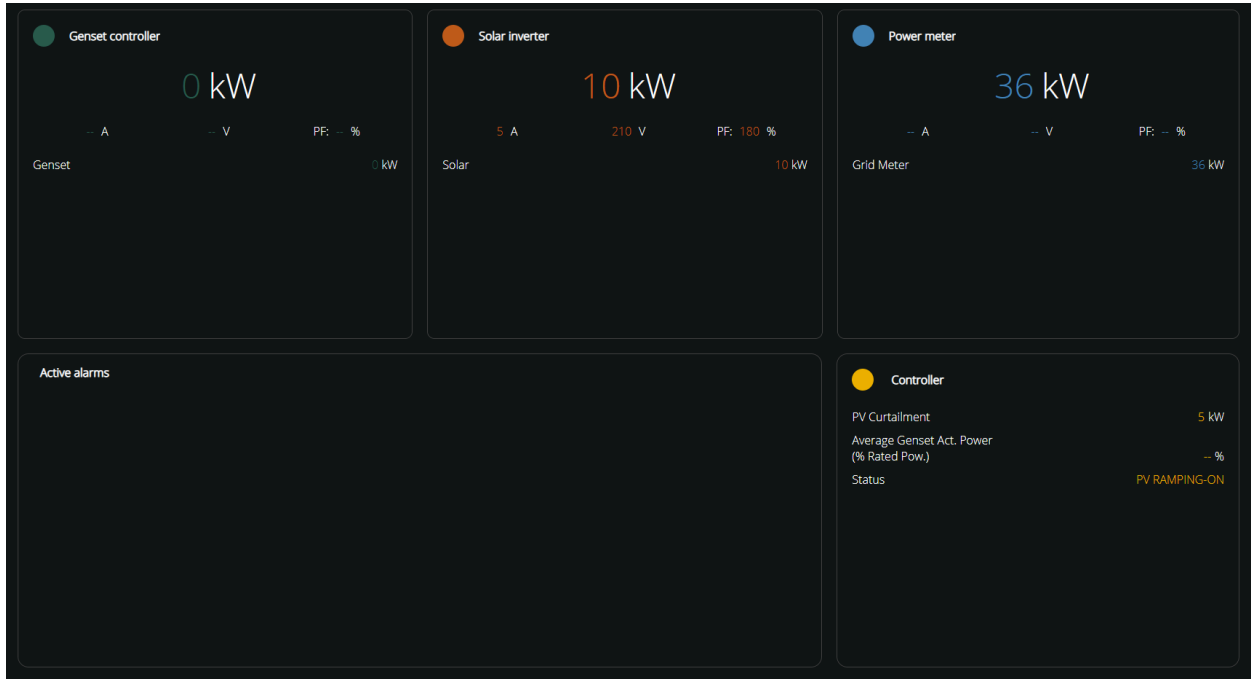

Fig. 48: Overview tab of Elum Configuration (EMS starting)

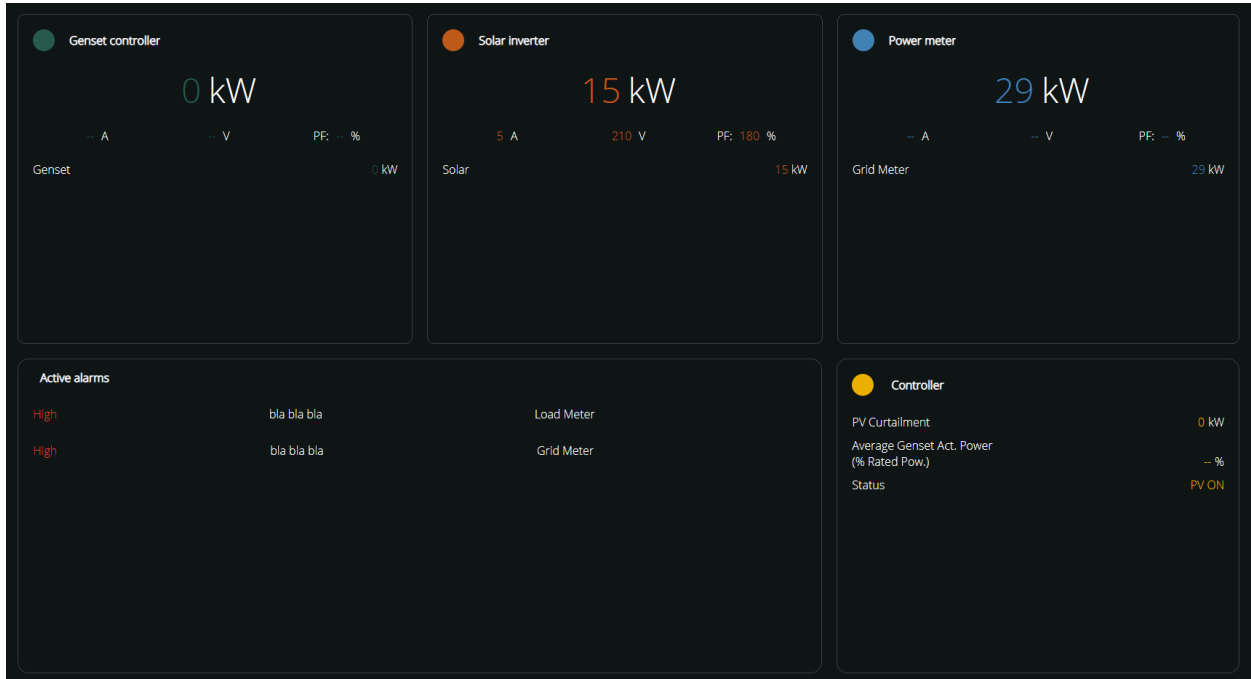

Fig. 49: Overview tab of Elum Configuration (EMS started)

7. Step 7: Functional tests

7.1. Test environment configuration

To proceed to the functional tests, you must keep your computer connected to the controller and you must be logged into Elum Configuration.

7.1.1. EMS status

Data acquisition must have already been launched and the EMS control status must be displayed as “PV ON”.

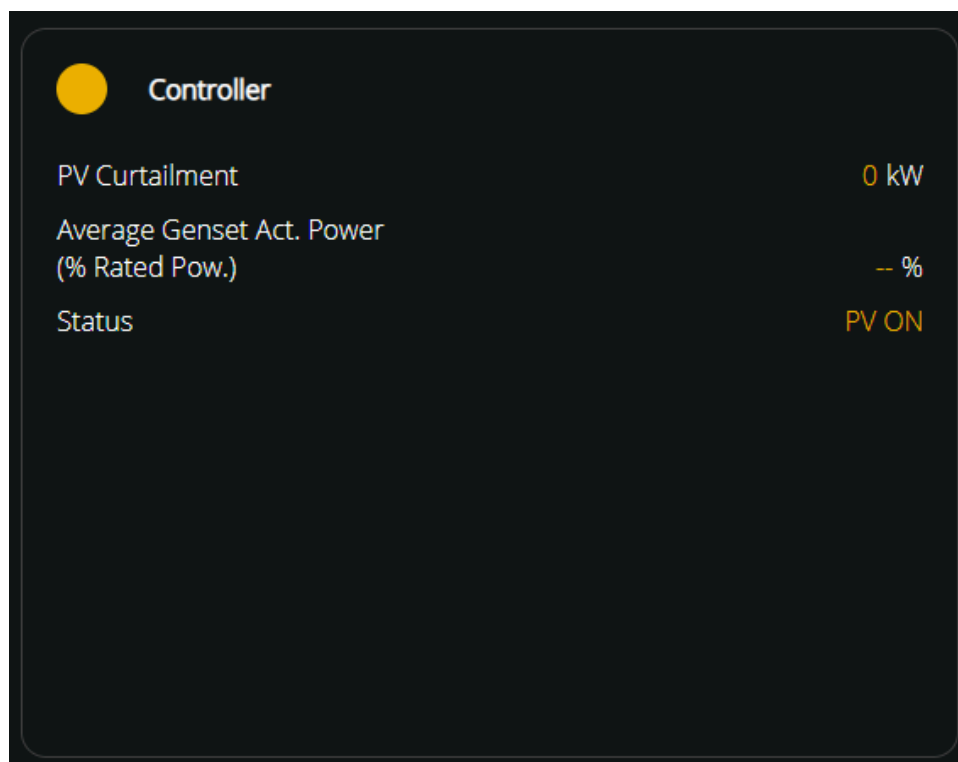

Fig. 50: Overview tab of Elum Configuration (EMS started)

7.1.2. PV injection

All the previous deployment process has been done with the PV injection shutdown. The functional tests configuration also requires you to remain PV injection shutdown at first.

7.1.3. Devices connection status

At this stage of the commissioning, you must have established the connection with all the equipment to be monitored and controlled by the Elum controller. You can monitor device status from the Elum Configuration Devices panel.

7.1.4. Consistency check up

From the Overview and Devices panel of Elum Configuration, real time data is displayed. The values are automatically refreshed. You must proceed to a consistency check, especially to validate the correct configuration of the power meters.



Power meters consistency check

Power meters correct installation requires a correct installation of the CTs and VTs.

1. CTs and VTs must be installed on the correct bus bar/wires, corresponding to the very point of interest
2. CTs must be installed in the correct direction
 - Grid Power consumption should always be represented by a positive value
 - Load Power consumption should always be represented by a positive value
 - Genset(s) Power production should always be represented by a positive value
3. CTs and VTs must correspond phase by phase, a swap between phases will impact the cos phi measurement

7.2. Test procedures

There are different test procedures according to EMS applications. Please follow instructions from the corresponding EMS application you selected on the Elum Configuration Control panel.

Each step of the procedure should be strictly followed according to the instructions indicated in this section.

At any step of the test procedure, if you have a different outcome than the expected outcome described at this step, contact the Elum Deployment team at support@elum-energy.com.

7.2.1. On-Grid (PV + Grid application)

Please find below the testing procedure, you must only move from one step to the following when your test results have been those described in this User Manual.

1. Log into Elum Configuration and access the Control panel by clicking on expanding the Settings and then clicking on Control from the left side menu.

Expected outcome: The Control panel must be displayed on screen.

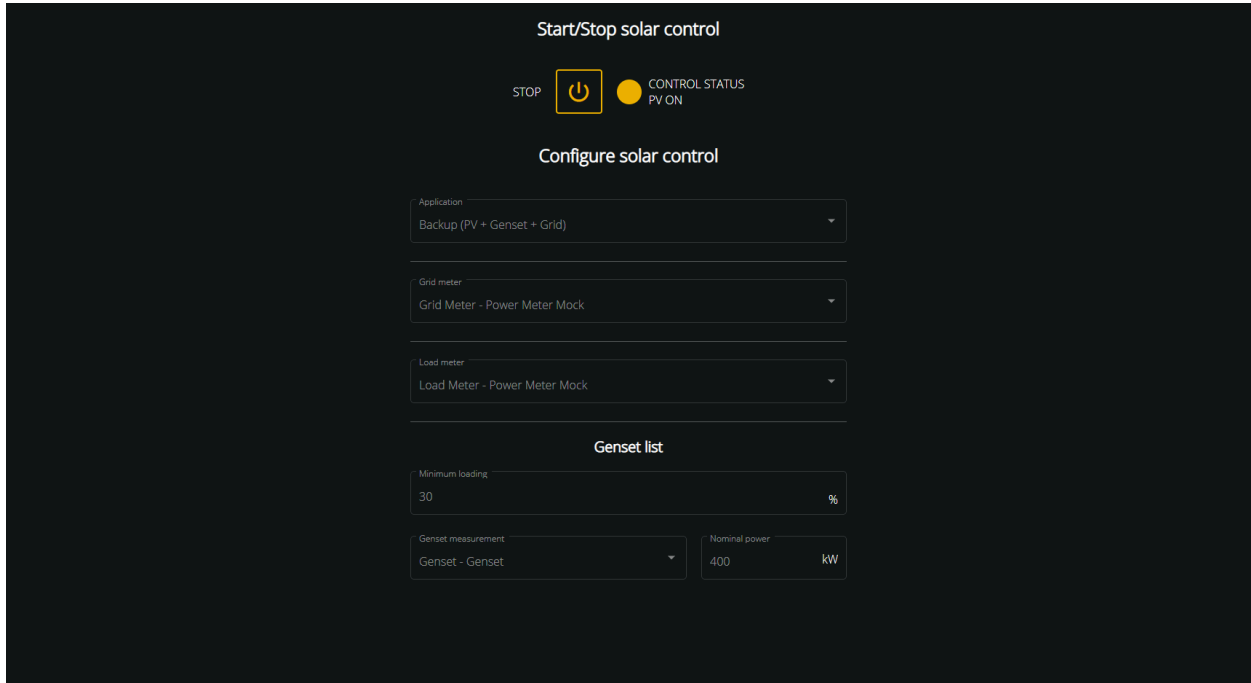

Fig. 51: Elum Configuration Control panel

2. Stop the EMS by clicking on 

Expected outcome: The EMS control status must be “PV RAMPING-OFF” then “PV OFF”.



When the EMS is stopped, the control features of the EMS are disabled and the PV inverters are curtailed to their minimum AC power output level. Datalogging features of the EMS remain active.

3. Start PV injection of one of the inverters.

Expected outcome: The AC power output of the inverter must remain below 1% of the PV inverter nominal output power.

4. If you have different brands and references of PV inverters, turn off all the inverters again and start over at this step 3 until you have tested independently all of the PV inverters brands and references.

Expected outcome: The AC power output of the inverter must remain below 1% of the PV inverter nominal output power, for each brand and reference of PV inverter.

5. Turn on all the PV inverters.

Expected outcome: The AC power output of each inverter must remain below 1% of the PV inverter nominal output power.

6. Start the EMS and PV injection by clicking on .

Expected outcome n°1: The EMS control status must first be displayed as “PV RAMPING-ON” for a few seconds and then as “PV ON”.

Expected outcome n°2: PV injection should start slowly.

7.2.2. Isolated (PV + Genset)

Please find below the testing procedure, you must only move from one step to the following when your test results have been those described in this User Manual.

1. Log into Elum Configuration and access the Control panel by clicking on expanding the Settings and then clicking on Control from the left side menu.

Expected outcome: The Control panel is displayed on screen.

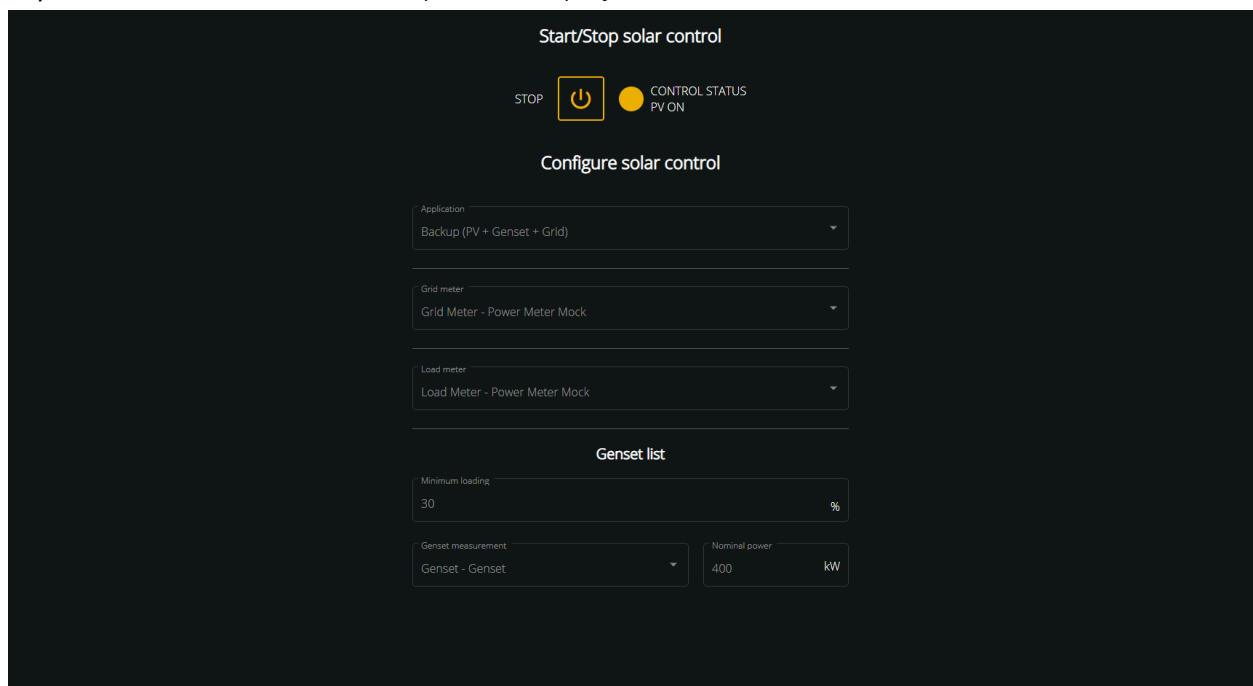

Fig. 52: Elum Configuration Control panel

2. Stop the EMS by clicking on .

Expected outcome: The EMS control status must be “PV RAMPING-OFF” then “PV OFF”.



When the EMS is stopped, the control features of the EMS are disabled and the PV inverters are curtailed to their minimum AC power output level. Datalogging features of the EMS remain active.

3. Start PV injection of one of the inverters.

Expected outcome: The AC power output of the inverter must remain below 1% of the PV inverter nominal output power.

4. If you have different brands and references of PV inverters, turn off all the inverters again and start over at this step 3 until you have tested independently all of the PV inverters brands and references.

Expected outcome: The AC power output of the inverter must remain below 1% of the PV inverter nominal output power, for each brand and reference of PV inverter.

5. Turn on all the PV inverters.

Expected outcome: The AC power output of each inverter must remain below 1% of the PV inverter nominal output power.

6. Start the EMS and PV injection by clicking on .

Expected outcome n°1: The EMS control status must first be displayed as “PV RAMPING-ON” for a few seconds and then as “PV ON”.

Expected outcome n°2: PV injection should start slowly.

7.2.3. Backup (PV + Genset + Grid)

Please find below the testing procedure, you must only move from one step to the following when your test results have been those described in this User Manual.

1. Manually change the power plant from “On grid, Grid connected” to “Off grid, Genset connected” configuration.

Expected outcome n°1: ePowerControl must have remained power supplied during transition from “On grid, Grid connected” to “Off grid, Genset connected” configuration.



You can verify if the ePowerControl is turned on by checking the Power LED on the front panel of the Central Computing Unit.

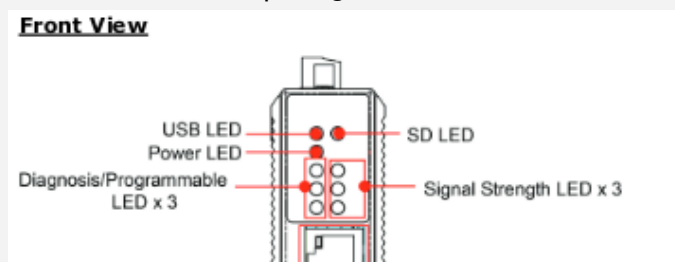

Expected outcome n°2: Grid, Load and Genset(s) power meters must be powered after gensets have started.

Expected outcome n°3: Genset(s) power meters monitoring values must be consistent i.e. equal to Load power meter monitoring values.

Expected outcome n°4: Grid power meter monitoring values must be consistent i.e. null.

2. Log into Elum Configuration and access the Control panel by clicking on expanding the Settings and then clicking on Control from the left side menu.

Expected outcome: The Control panel must be displayed on screen.

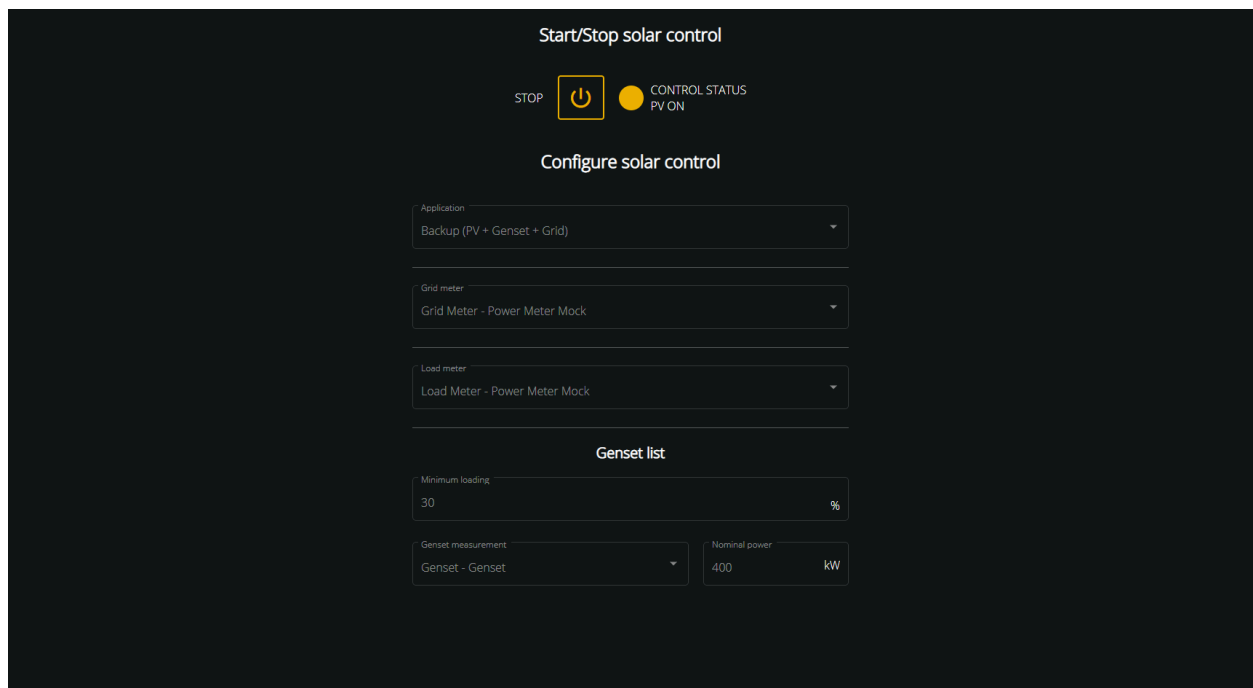

Fig. 53: Elum Configuration Control panel

3. Stop the EMS by clicking on 

Expected outcome: The EMS control status must be displayed as “PV RAMPING-OFF” then “PV OFF”.



When the EMS is stopped, the control features of the EMS are disabled and the PV inverters are curtailed to their minimum AC power output level. Datalogging features of the EMS remain active.

4. Start PV injection of one of the inverters.

Expected outcome: The AC power output of the inverter must remain below 1% of the PV inverter nominal output power.

5. If you have different brands and references of PV inverters, turn off all the inverters again and start over at this step 3 until you have tested independently all of the PV inverters brands and references.

Expected outcome: The AC power output of the inverter must remain below 1% of the PV inverter nominal output power, for each brand and reference of PV inverter.

6. Turn on all the PV inverters one by one.

Expected outcome: The AC power output of each inverter must remain below 1% of the PV inverter nominal output power.

7. Start the EMS and PV injection by clicking on .

Expected outcome n°1: The EMS control status must first be displayed as “PV RAMPING-ON” for a few seconds and then as “PV ON”.

Expected outcome n°2: PV injection should start slowly.

8. Manually change the power plant from “Off grid, Genset connected” to “On grid, Grid connected” configuration.

Expected outcome n°1: ePowerControl must have remained power supplied during transition from “Off grid, Genset connected” to “On grid, Grid connected” configuration.

Expected outcome n°2: Grid, Load and Genset(s) power meters must be powered after going back to “On grid, Grid connected” configuration.

7.3. Tests conclusion

Once the test procedures have been strictly followed and that each testing step has led to the Expected outcome described in this document, the EMS can be considered as fully commissioned.

Results and comments should be saved in the Test Matrix for the record.

7.3.1. On-Grid (PV + Grid application) test matrix

Steps	Expected outcome	Observed outcome
-------	------------------	------------------

1. Log into Elum Configuration and access the Control panel	1.1. The Control panel must be displayed on screen.	
2. Stop the EMS by clicking on the EMS On/Off Button	2.1. Expected outcome: The EMS control status must be displayed as “PV OFF”.	
3. Start PV injection of one of the inverters	3.1 The AC power output of the inverter must remain below 1% of the PV inverter nominal output power.	
4. If you have different brands and references of PV inverters, turn off all the inverters again and start over at this step 3 until you have tested independently all of the PV inverters brands and references.	4.1. The AC power output of the inverter must remain below 1% of the PV inverter nominal output power, for each brand and reference of PV inverter.	
5. Turn on all the PV inverters one by one.	5.1. The AC power output of each inverter must remain below 1% of the PV inverter nominal output power.	
6. Start the EMS by clicking on the EMS On/Off Button	6.1. The EMS control status must first be displayed as “PV RAMPING-ON” for a few seconds and then as “PV ON”.	
	6.2. PV injection should start slowly	

7.3.2. Islanded (PV + Genset) test matrix

Steps	Expected outcome	Observed outcome
1. Log into Elum Configuration and access the Control panel	1.1. The Control panel must be displayed on screen.	
2. Stop the EMS by clicking on the EMS On/Off Button	2.1. Expected outcome: The EMS control status must be displayed as “PV OFF”.	
3. Start PV injection of one of the inverters	3.1 The AC power output of the inverter must remain below 1% of the PV inverter nominal	

	output power.	
4. If you have different brands and references of PV inverters, turn off all the inverters again and start over at this step 3 until you have tested independently all of the PV inverters brands and references.	4.1. The AC power output of the inverter must remain below 1% of the PV inverter nominal output power, for each brand and reference of PV inverter.	
5. Turn on all the PV inverters one by one.	5.1. The AC power output of each inverter must remain below 1% of the PV inverter nominal output power.	
6. Start the EMS by clicking on the EMS On/Off Button	6.1. The EMS control status must first be displayed as “PV RAMPING-ON” for a few seconds and then as “PV ON”.	
	6.2. PV injection should start slowly	

7.3.3. Backup (PV + Genset + Grid) test matrix

Steps	Expected outcome	Observed outcome
1. Manually change the power plant from “On grid, Grid connected” to “Off grid, Genset connected” configuration.	1.1. ePowerControl must have remained power supplied during transition from “On grid, Grid connected” to “Off grid, Genset connected” configuration.	
	1.2. Grid, Load and Genset(s) power meters must be powered after gensets have started.	
	1.3. Genset(s) power meters monitoring values must be consistent i.e. equal to Load power meter monitoring values.	
	1.4. Grid power meter monitoring values must be	

	consistent i.e. null.	
2. Log into Elum Configuration and access the Control panel	2.1. The Control panel must be displayed on screen.	
3. Stop the EMS by clicking on the EMS On/Off Button	2.1. Expected outcome: The EMS control status must be displayed as “PV OFF”.	
4. Start PV injection of one of the inverters	4.1 The AC power output of the inverter must remain below 1% of the PV inverter nominal output power.	
5. If you have different brands and references of PV inverters, turn off all the inverters again and start over at this step 3 until you have tested independently all PV inverters brands and references.	5.1. The AC power output of the inverter must remain below 1% of the PV inverter nominal output power, for each brand and reference of PV inverter.	
6. Turn on all the PV inverters one by one.	6.1. The AC power output of each inverter must remain below 1% of the PV inverter nominal output power.	
7. Start the EMS by clicking on the EMS On/Off Button	7.1. The EMS control status must first be displayed as “PV RAMPING-ON” for a few seconds and then as “PV ON”.	
	7.2. PV injection should start slowly	
8. Manually change the power plant from “Off grid, Genset connected” to “On grid, Grid connected” configuration.	8.1. ePowerControl must have remained power supplied during transition from “Off grid, Genset connected” to “On grid, Grid connected” configuration.	
	8.2. Grid, Load and Genset(s) power meters must be powered after going back to “On grid, Grid connected” configuration.	

8. Elum Configuration after the commissioning

8.1. Accessing Elum Configuration

After the deployment of the ePowerControl, the Elum Configuration interface remains accessible at any time.

1. Connect your laptop to the port LAN2 of the Central Computing unit.
2. Open your favorite web browser and enter **192.168.4.127** in the URL bar

8.2. Elum Configuration Overview panel

When accessing the Elum Configuration platform you arrive on the Overview panel, giving some synoptic details about your PV Hybrid power plant.

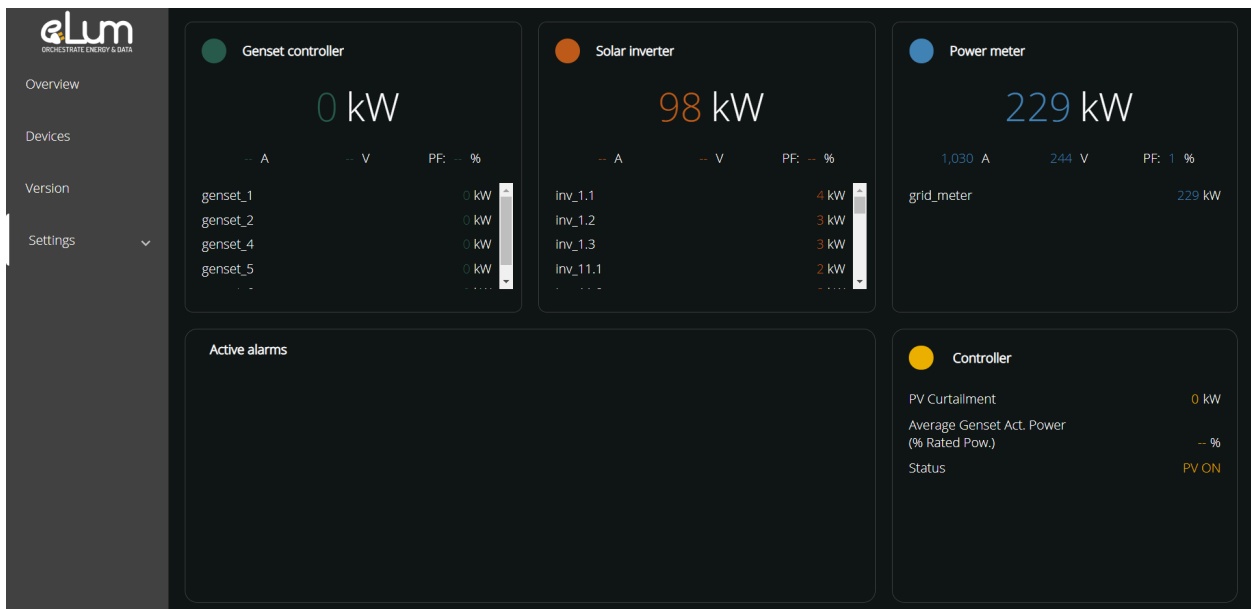

Fig. 54: Elum Configuration Overview panel

8.2.1. Genset controller widget

Lists all the genset devices connected to the ePowerControl and their current power production. Also shows their aggregated power production.

8.2.2. Solar inverter widget

Lists all the inverter devices connected to the ePowerControl and their current power production. Also shows their aggregated power production.

8.2.3. Power meter widget

Lists all the power meters devices connected to the ePowerControl and their current power measurement, and shows their aggregated power measurements.

8.2.4. Controller widget

Lists some specific KPIs from the EMS.

- **PV Curtailment:** Total active output power curtailment of all inverters connected to the ePowerControl.
- **Average Genset Act. Power** (% Rated Power): Average loading of all gensets connected to the ePowerControl balanced by their nominal rated power.
- **Status:** Solar control current status.

8.3. Elum Configuration menus

You can navigate to the other panels just by clicking on them from the left side menu.

Accessing the Overview panel, so as the Devices (read only) and the Version Panel does not require any password. However, accessing any panel from the Settings will require you to log in as an Advanced User by indicating the ePowerControl password.

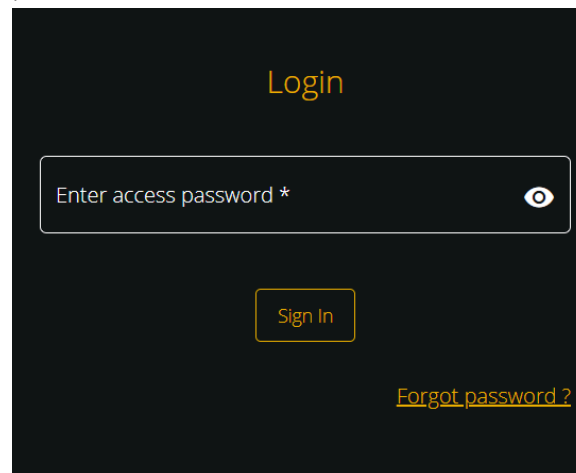

Fig. 55: Elum Configuration Login pop up panel

An Advanced User can log out at any time by clicking on the button  on the bottom left corner.



Forgot password?

If the Advanced User password was forgotten, a back-up password can be generated by Elum upon request. This back-up password will be valid for 24h, you can use it to login and set a new password from the Password panel.

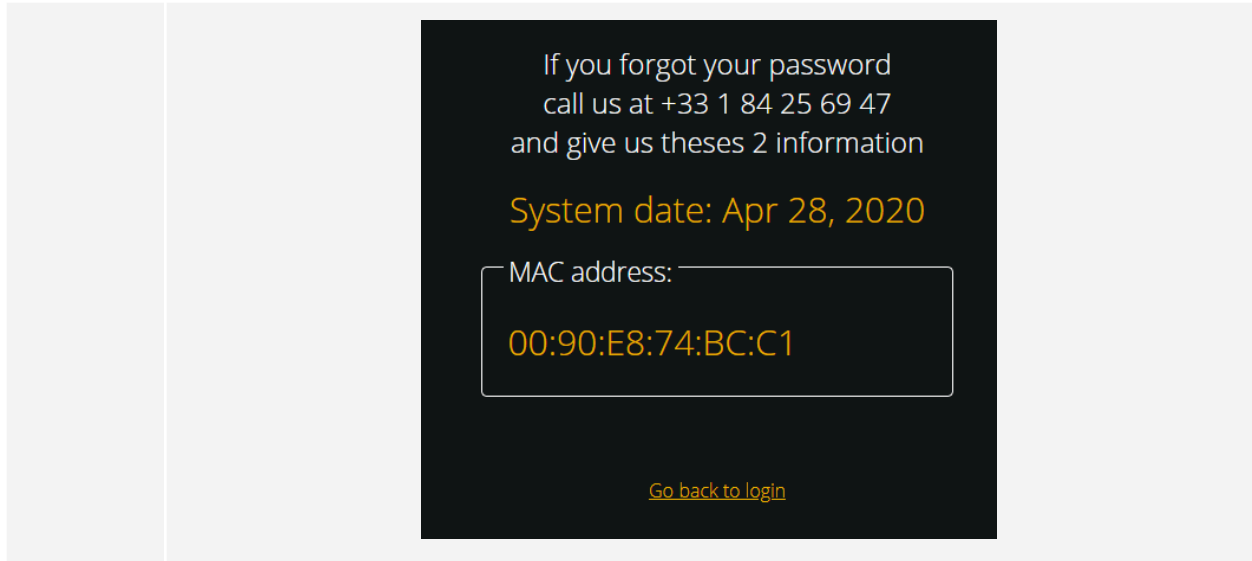

You will find below a description of each Elum Configuration panel.

8.3.1. Devices

The Devices panel displays the list of all equipment connected to the ePowerControl and their current connection status.

Name	Reference	Type	Status
Genset	Genset	Genset controller	Connected
Load Meter	Power Meter	Power meter	Connected
Grid Meter	Power Meter	Power meter	Connected
Solar	Solar	Solar inverter	Connected

Fig. 56: Elum Configuration Devices panel (1/2)

By clicking on any of the devices you can access its detailed live data.

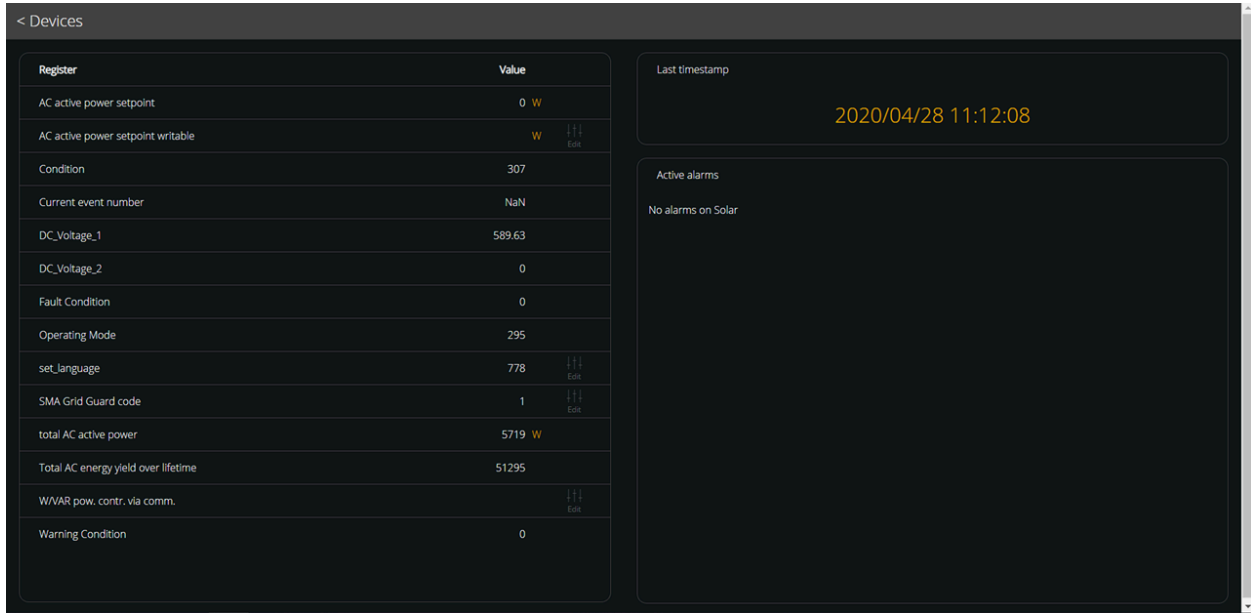

Fig.57: Elum Configuration Devices panel (2/2)

Live data of all accessible read and write registers of this specific device will be displayed.

Some of the registers can be edited by clicking on . Editing registers requires the PV injection to be turned off prior to the edition. This can be done from the Control panel. Do not forget to turn on PV production again after editing the register.

By doing so you will be asked to indicate the new value to be assigned to this specific register of this specific device and then confirm your choice.

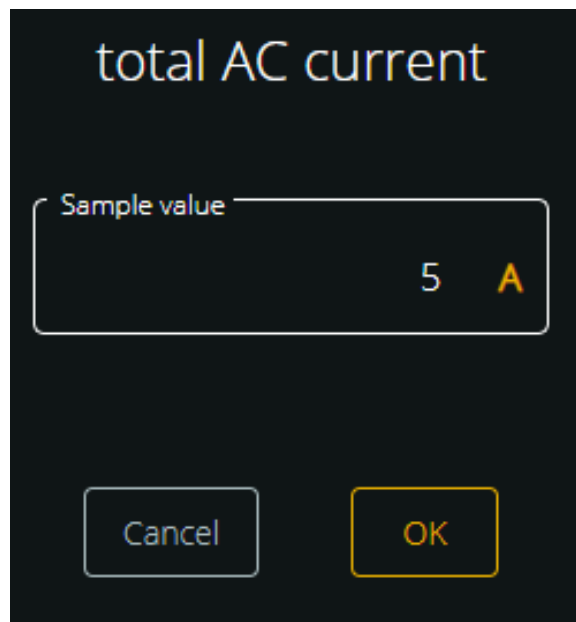

Fig. 58: Register edition from Device panel

8.3.2. Version

The Devices panel displays the version of the Elum firmware packages installed on your ePowerControl.



Fig. 59: Elum Configuration Version panel

8.3.3. Control

The Control panel gives an Advanced User access to the settings of the EMS.

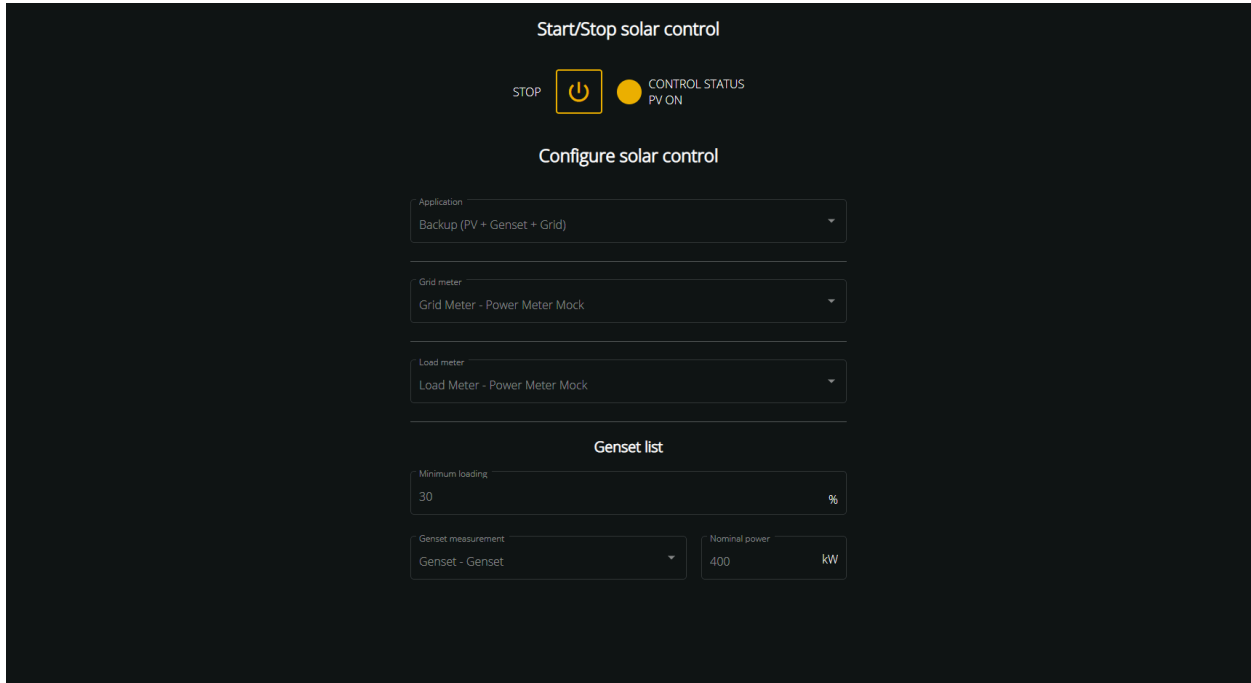

Fig. 60: Elum Configuration Control panel

Start/stop solar control

PV production can be manually turned ON or OFF at any time. This can be required for example if you need to edit some Devices register, modify EMS parameters or change the Network setup.

Solar control status

There are four different possible solar control status:

- PV OFF, PV injection is currently turned OFF, it will remain OFF as long as the solar control is not manually turned ON again.

START

CONTROL STATUS
PV OFF

- PV RAMPING ON, PV injection is currently being turned ON, it will be ON after PV ramping ON.

START

CONTROL STATUS
PV RAMPING-ON

- PV ON, PV injection is currently turned ON, it will remain ON as long as the solar control is not manually turned OFF again



- PV RAMPING OFF, PV injection is currently being turned OFF, it will be OFF after PV smoothing.

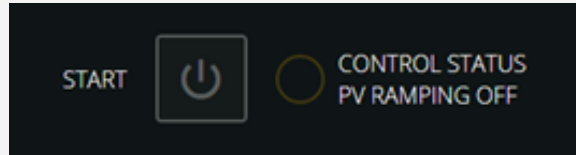

Configure solar control

The minimum genset loading can be manually edited from the Control Tab. The critical devices identification i.e. grid power meter and gensets can also be reviewed and modified from the Control panel. Editing such configuration requires the PV injection to be turned off prior to the edition. This can be done from the Control panel. Do not forget to turn on PV production again after editing the register.

8.3.4. Network

The Network panel gives an Advanced User access to the Network configuration. When PV injection is ON, this configuration can be read only. This configuration can be edited only when PV injection is OFF.

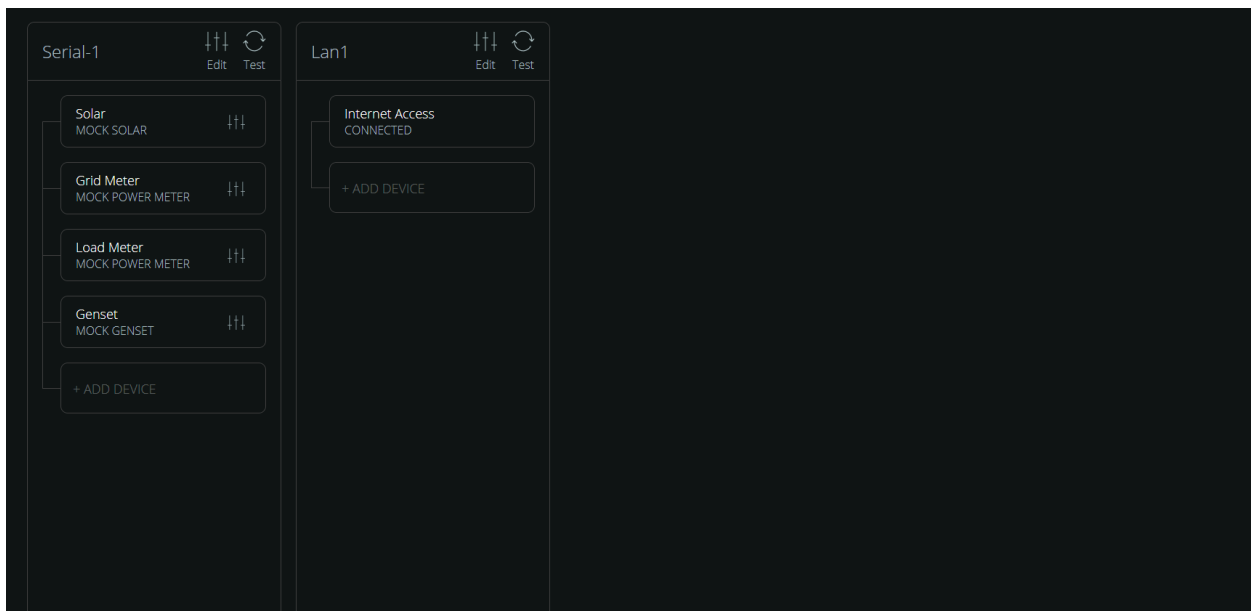

Fig. 61: Elum Configuration Network panel

8.3.5. Date

The Network panel allows an Advanced User to access the Date & Time, but also Timezone settings.

If the explorer is connected to the internet, it will automatically set itself to internet time (via NTP). Otherwise it is possible to set the time manually via the interface.

The date & time set on the data logger is important for the timestamping of the monitored values.



The timestamps are indicated in UTC (the time zone therefore has no impact), the value taken is the one in the middle of the reading operation: if the reading starts at 12:35'30'' and lasts 3 seconds (to read all the equipment), the same timestamp will be assigned to all the variables: 12:35'31.5''.

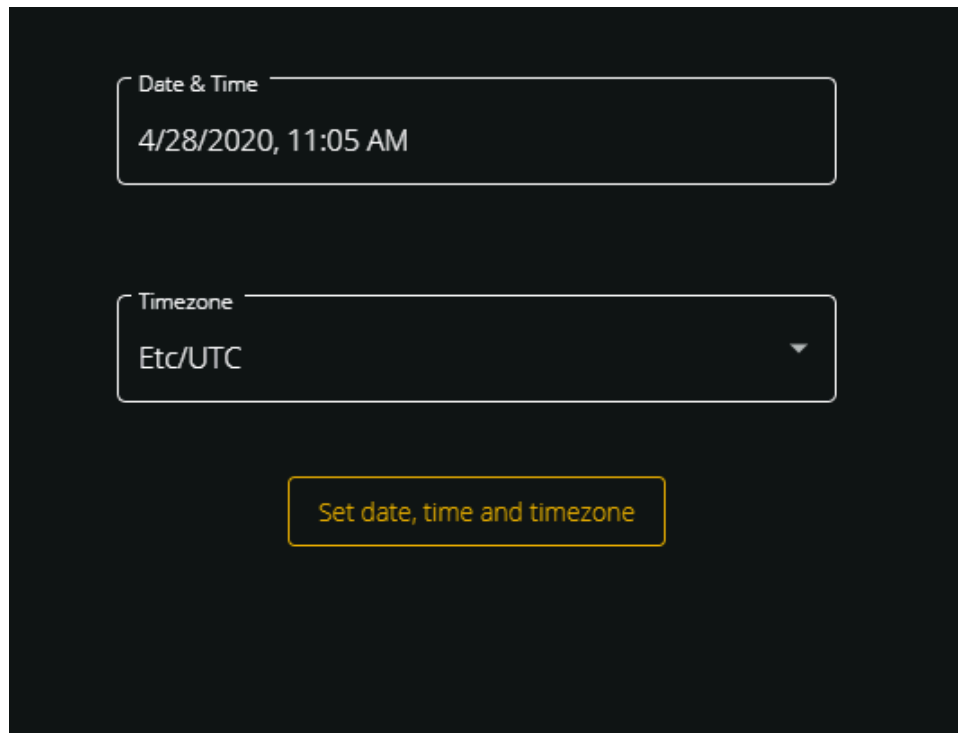

Fig. 62: Elum Configuration Date panel

8.3.6. Password

The Password panel allows an Advanced User to set a new password.

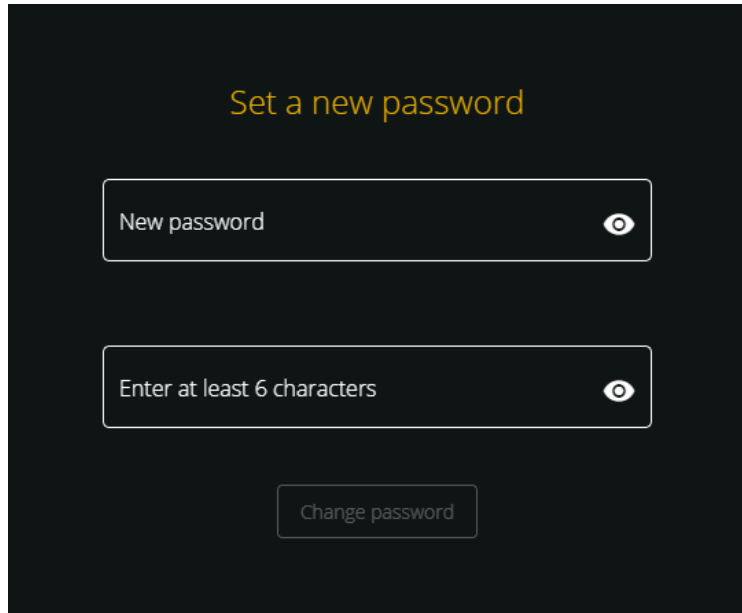

Fig. 63: Elum Configuration Password panel

8.3.7. Site

The Site panel allows an Advanced User to modify the site settings, new settings will overwrite previous site settings.

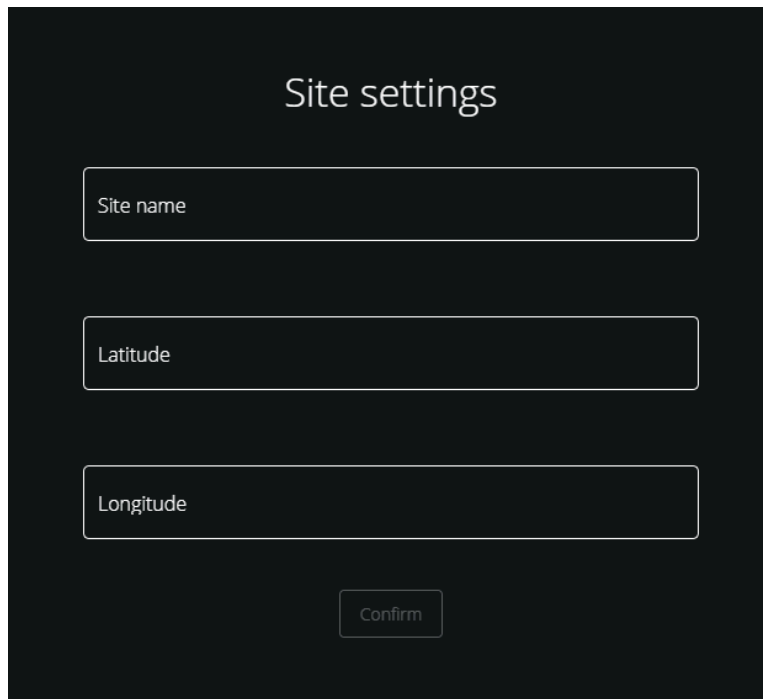

Fig. 64: Elum Configuration Site panel

8.3.8. Data Forwarding

If the ePowerLog is equipped with the data forwarding feature, the Data forwarding panel allows the user to change the data forwarding settings already set during the commissioning.

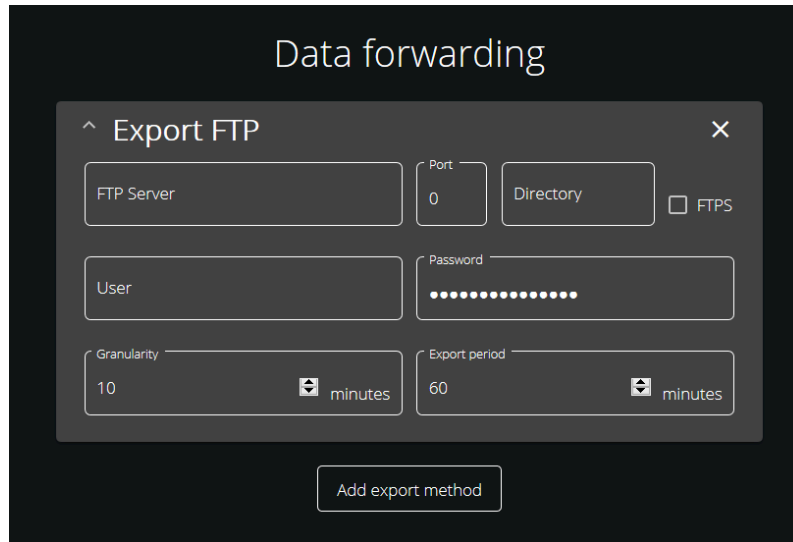

Fig. 65: Elum Configuration Data forwarding panel

8.3.9. Advanced

The Advanced panel allows an Advanced User to reset the ePowerControl configuration to factory settings.



All your personal data will be lost. No restoring will be possible.

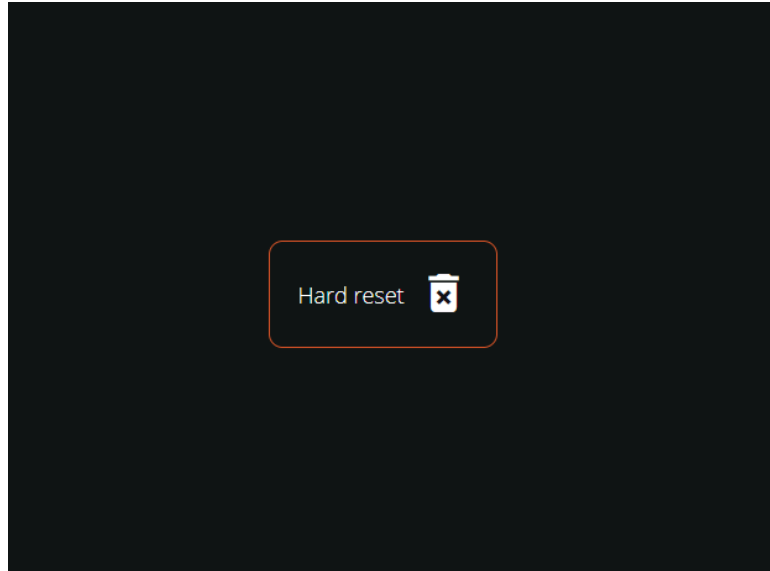

Fig. 66: Elum Configuration Advanced panel (1/2)

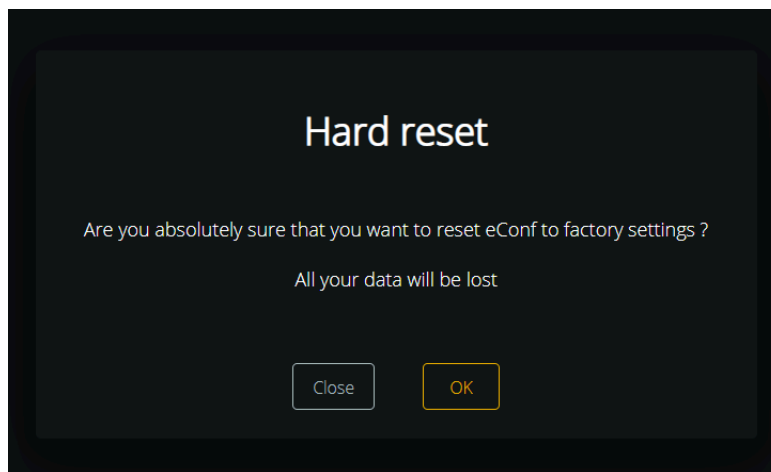

Fig. 67: Elum Configuration Advanced panel (2/2)

9. Appendix A: New equipment driver integration by Elum

9.1. Objectives

Elum Explorers can communicate with a wide range of devices under reserve of compatibility in terms of communication protocol and communication ports.

Table X: Elum Explorers compatibility requirements

Communication Port	Communication Protocol
RS232	Modbus RTU
RS485	Modbus RTU
RS485	Solivia
Ethernet	Modbus TCP
Ethernet	SNMP v2

9.2. Integration procedures

The integration process depends on the device to be integrated. Please follow instructions according to the equipment classification which new driver will be integrated by Elum.

Table X+1: Critical device classification criterias

Critical devices when commissioning ePowerLog:	Critical devices when commissioning ePowerControl:
N/A	Any device of the following type: <ul style="list-style-type: none"> - PV Inverter - Genset controller - Battery Inverter - Load Power Meter - Grid Power Meter - Genset Power Meter



For critical device driver integration by Elum, please notice that you must book a specific date and time with the Elum Deployment team for a new equipment driver integration by Elum, at least 10 days prior to the Explorer commissioning

9.2.1. Non-critical device

1. Send device manufacturer documentation to Elum, at least 10 prior to the Explorer shipping date.

The following documents will be asked for a new device integration by Elum

- Datasheet
- User Manual
- Communication protocol technical specification, i.e. Modbus register map for devices communicating through Modbus RTU or Modbus TCP and the Management Information Base file (MIB) for devices communicating through SNMP v2.

Elum Deployment team prepares the driver, and pre-embeds the new driver(s) in the Explorer shipped to you.



When shipping your Explorer, Elum pre-embeds all its already integrated devices drivers plus your project specific drivers.

After the Elum Explorer has been sent to you, no additional equipment driver will be added to your Elum Explorer.

2. Proceed to the commissioning of your Explorer. The communication setup and tests with the new device must be established exactly in the same way as for the other devices.

Elum Deployment team will proceed to the QA analysis and to a consistency check up of the new driver.



The device must be stated as “Connected” from the Overview Panel of Elum Configuration at the end of the commissioning. However if some of the real time monitored values are non consistent please contact the Elum Deployment team at support@elum-energy.com. Elum Deployment team will be fully autonomous after the commissioning of your system has been completed, and if needed we can proceed to the driver update remotely, this does not require the presence of technical teams on site.

9.2.2. Critical device

1. Send device manufacturer documentation to Elum, at least 10 days prior to the Explorer shipping date.

The following documents will be asked for a new device integration by Elum

- Datasheet
- User Manual

- Communication protocol technical specification, i.e. Modbus register map for devices communicating through Modbus RTU or Modbus TCP and the Management Information Base file (MIB) for devices communicating through SNMP v2.

Elum Deployment team prepares the driver, and pre-embeds the new driver(s) in the Explorer shipped to you.



When shipping your Explorer, Elum pre-embeds all its already integrated devices drivers plus your project specific drivers.

After the Elum Explorer has been sent to you, no additional equipment driver will be added to your Elum Explorer.

2. Book a specific date and time with the Elum Deployment team for a new equipment driver integration by Elum, at least 10 days prior to the Explorer commissioning.
3. Proceed to the commissioning of your Explorer until you complete Step 6: Configuring the ePowerControl on Elum Configuration. The communication setup and tests with the new device must be established exactly in the same way as for the other devices.
7. Log into Elum Configuration and access the Control panel by clicking on expanding the Settings and then clicking on Control from the left side menu.

Expected outcome: The Control panel must be displayed on screen.

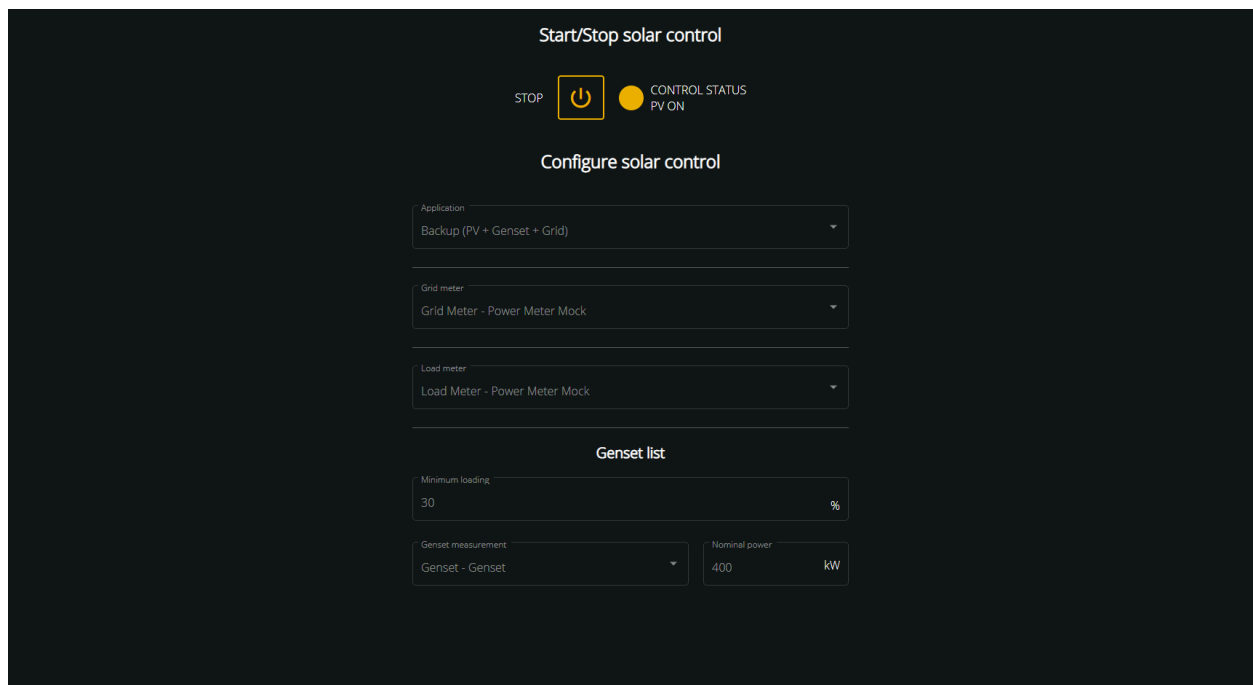

Fig. 67: Elum Configuration Control panel

8. Stop the EMS by clicking on 

Expected outcome: The EMS control status must be displayed as “PV RAMPING-OFF” then “PV OFF”.



When the EMS is stopped, the control features of the EMS are disabled and the PV inverters are curtailed to their minimum AC power output level. Datalogging features of the EMS remain active.

4. Contact Elum Deployment Team

Elum Deployment Team will autonomously proceed to some further communication tests on the driver. Some modification in the device configuration might be needed, so please stand by on site. You will be informed as soon as those additional communication tests have been completed.



During this step, when the Elum Deployment team will be performing his tests, the Elum Configuration platform might not be available.

5. Proceed to the Step 7: Functional tests.

10. Appendix B: Ten mistakes to avoid

Table X+2: Ten mistakes to avoid

Mistake	Diagnosis	How to fix it
Neglected RS485 wiring	<ul style="list-style-type: none"> - Communication with the device cannot be established - Communication with the device is intermittent 	<p>Connecting RS485 Devices</p> <p>Review Central Computing Unit pin and serial port identification.</p> <p>Review wiring according to Elum and RS485 standard guidelines.</p> <p>Review termination of data wires.</p> <p>Review shielding.</p>
Modbus communication not enabled on slave device	<ul style="list-style-type: none"> - Communication with the device cannot be established - Communication with the device is intermittent 	<p>Refer to the <i>Device Connection & Configuration Specific Instructions</i>.</p>
Dynamic power control not enabled on inverter	<ul style="list-style-type: none"> - Monitoring of the device works fine but control fails 	<p>Refer to the <i>Device Connection & Configuration Specific Instructions</i>.</p>
UPS wiring	<ul style="list-style-type: none"> - Elum Controller reboots when switching from “On grid - Grid connected mode” and to “Off grid - Genset connected mode”. - Elum Controller reboots when switching from “Off grid - Genset connected mode” to “On grid - Grid connected mode”. 	<p>Power Supply</p> <p>Power source supplying the controller must be taken from the load side so that the controller is power supplied both when operating on “On grid - Grid connected mode” and on “Off grid - Genset connected mode”.</p> <p>If an UPS is used, the power source of the UPS must follow the same rule.</p> <p>For ePowerControl SD, HFS and MC the use of an UPS is mandatory.</p>

<p>Reverse power protection configuration</p>	<ul style="list-style-type: none"> - Wrong breaker control - Breaker control fails 	<p>Refer to the <i>Device Connection & Configuration Specific Instructions</i> and third party documentation.</p> <p>Safety warnings</p> <p>The ePower Control is NOT an electrical protection. It does not replace an adequate protection of diesel generators against power reversal, nor a properly configured/installed protection relay, nor a properly configured/installed genset controller integrating the reverse current protection functionality. If necessary, please install protection relays against reverse power.</p>
<p>Power meters power supply wiring</p>	<ul style="list-style-type: none"> - Power meter is turned off after switching from “On grid - Grid connected mode” and to “Off grid - Genset connected mode”. - Power meter is turned off after switching from “Off grid - Genset connected mode” to “On grid - Grid connected mode”. 	<p>AC Meter 5A provided by Elum</p> <p>AC Meter 333mV provided by Elum</p> <p>The auxiliary power supply on the meter enables it to always be powered up whether the plant is operating on grid or on gensets. Power meters monitoring the grid, the load or gensets should always be powered up. One of those power meters being suddenly turned off would turn the ePowerControl into a fail safe mode, curtailing PV production.</p>
<p>Power meters VTs/CTs ratio</p>	<ul style="list-style-type: none"> - Power meter monitoring values are inconsistent 	<p>AC Meter 5A provided by Elum</p> <p>When installing a EM330-DIN.AV5.3.H.S1.X, Carlo Gavazzi:</p>

		<p>Ct rAtlo, Current transformer ratio: You can obtain this ratio by dividing the primary current by the secondary current. As an example, when using 200 A to 5 A CTs, the ratio should be set to 40.</p> <p>Vt rAtlo, Voltage transformer ratio: You can obtain this ratio by dividing the primary voltage by the secondary voltage. As an example, when installing the power meter using no VTs, the ratio should be set to 1.</p> <p>AC Meter 333mV provided by Elum</p> <p>When installing a EM210-72D.MV5.3.X.OS.X, Carlo Gavazzi:</p> <p>SEnSOr , CT type: As an example, when installing the power meter with Rogowski coil CTs, the type should be set to roG</p> <p>Ct Prin, Current transformer maximum current input: As an example, when installing the power meter with Rogowski coil 4000A, the type should be set to 4,00k.</p> <p>Vt rAtlo, Voltage transformer ratio: You can obtain this ratio by dividing the primary voltage by the secondary voltage. As an example, when installing the power meter using no VTs, the ratio should be set to 1.</p>
<p>Power meters VTs/CTs wiring</p>	<p>- Cos phi is inconsistent, but the rest of the power meter</p>	<p>AC Meter 5A provided by Elum</p>

	<p>monitoring values are consistent</p>	<p>AC Meter 333mV provided by Elum</p> <p>Rearrange CTs and VTs wiring by respecting phases order.</p>
<p>Negative power monitoring not enabled on grid meter</p>	<ul style="list-style-type: none"> - Power meter monitoring values signs are inconsistent 	<p>AC Meter 5A provided by Elum</p> <p>When installing a EM330-DIN.AV5.3.H.S1.X, Carlo Gavazzi:</p> <p>MEASurE, Measurement type: To be set to “b”</p> <p>AC Meter 333mV provided by Elum</p> <p>When installing a EM210-72D.MV5.3.X.OS.X, Carlo Gavazzi:</p> <p>APPLiC, Measurement application: To be set to “E”.</p>
<p>Local internet network configuration or SIM card contract invalid</p>	<ul style="list-style-type: none"> - Local internet access fails - Wireless internet network fails 	<p>Configuring a wired internet connection</p> <p>To be able to join our back end, the controller must have these ipv4 outgoing accesses:</p> <ul style="list-style-type: none"> - ICMP - TCP ports: 53, 80, 443, 4505, 4506 - UDP ports: 53, 123, 1195 <p>Configuring a cellular internet connection</p> <p>The GSM/3G kit is pre-embedded in the Central Computing Unit. You also need a SIM card with a subscription to a valid “data” contract.</p>

		<p>ePowerControl must be turned off each time a SIM card is inserted or removed from the SIM card slot. In addition, if for any reason it is necessary to change the SIM card for another one, it will be necessary to perform an empty start of the ePowerControl.</p> <p>Appendix C: Internet Speed Test</p>
--	--	--

11. Appendix C: Internet Speed Test

11.1. Internet Speed Test Requirements for Elum Explorers

Function of the internet access point	Max packet loss	Minimum upload rate	Minimum download rate	ePowerLog	ePowerControl SD/ZE/HFS	ePowerControl MC/PPC
Firmware update	10%	any	50 ko/s	X	X	X
Data upload to Archive	10%	200 ko/s	-	X (ePowerMonitor)	X (ePowerMonitor)	X (ePowerMonitor)
Remote Commissioning or remote Assistance using SSH session	10%	25 ko/s	25 ko/s	X (unstable version)		X
FTP push to remote server	10%	50 ko/s	-	X (FTP)	X (FTP)	X (FTP)
Remote assistance using eConf	10%	200 ko/s	-	X	X	NA

11.2. Test protocol to be performed

Prerequisite: disable your internet browser adblock if you have one active

1. **At precise Elum controller future location**, access from your mobile / computer to the following website: <https://sourceforge.net/speedtest/>
2. Click on the button Test now:



Internet Speed Test

Welcome to the SourceForge Speed Test. This speed test is uniquely designed to test your current Internet connection speed for Latency/Ping, Jitter, Download Speed, Upload Speed, Buffer Bloat, and Packet Loss. Upon completion, you will be notified as to what types of services your connection is capable of handling, as well as additional reports about your connection. This HTML5 speed test does not require Flash or Java, and works on all devices including tablets and smartphones. Please click the 'Test Now' button below to begin the test! This test utilizes WebSockets for latency, jitter, and buffer bloat measurements. For best results close out other open tabs in your browser and ensure your computer is mostly idle.

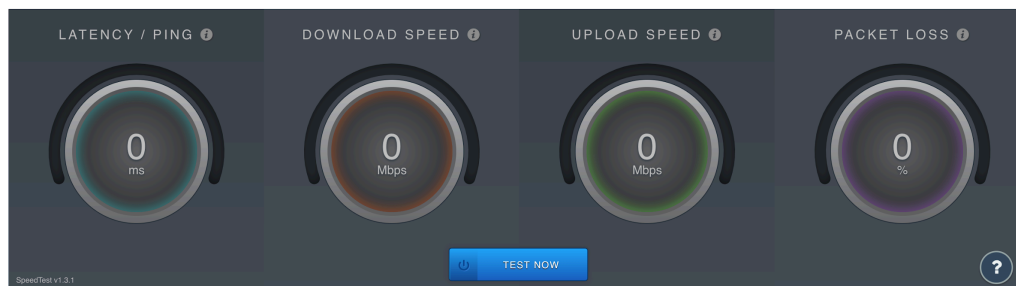

3. Wait for the test launch:

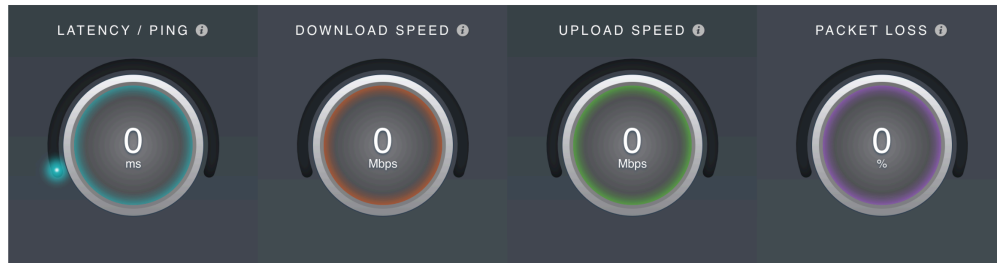

4. Check that the test is going to the end and **take this as a screenshot (N1)**:

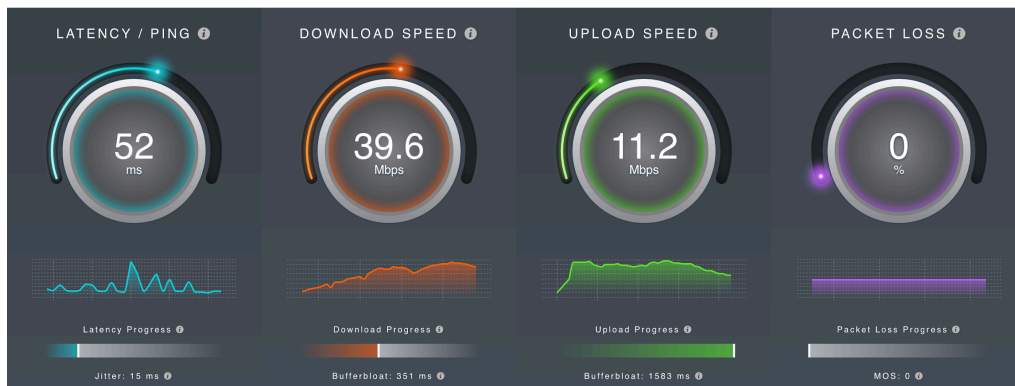

5. Once the test is complete, scroll down and click on the “view details” button:

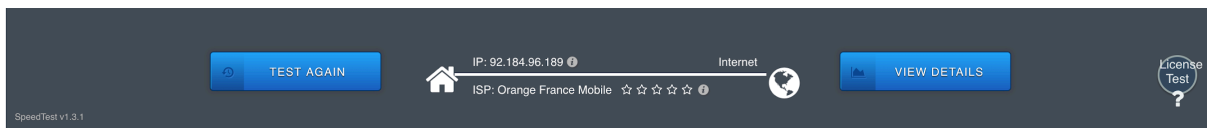

6. Take the **following 4 screenshots (N2/N3/4/N5)** and send them to us:

- **N2: Round Trip Time**

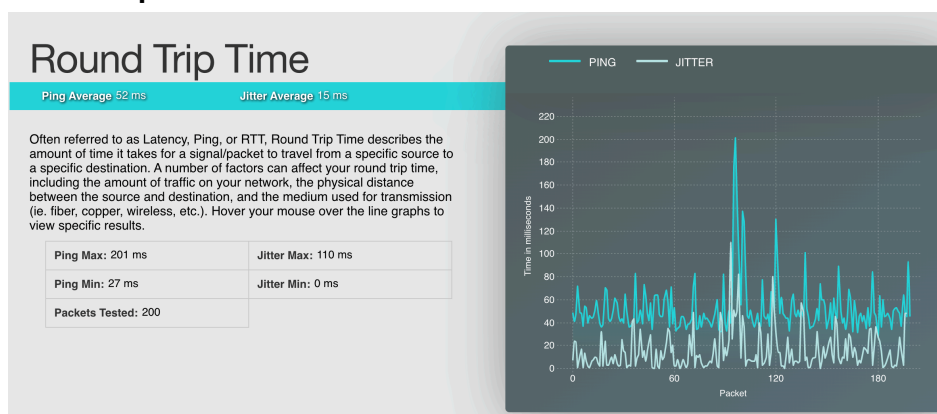

- **N3: Download Quality**

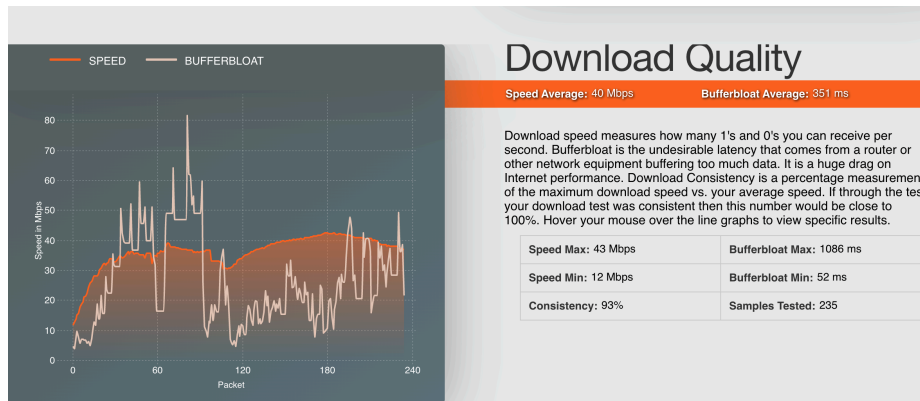

- **N4: Upload Quality**

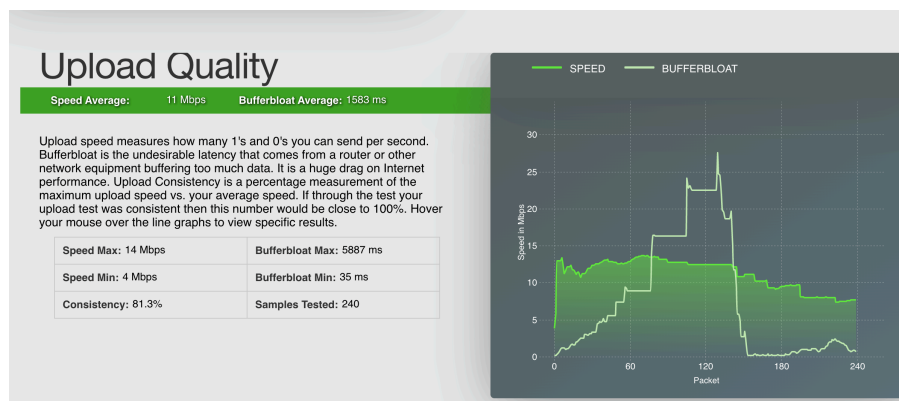

- **N5: Internet Quality**

