



# Quick Start Guide

Product installation instructions

Version 2023



## About this document

This document covers the following Elum products:

- ePowerLog: DL 3000, DL 10 000

It serves the purpose of providing the users with a simplified guideline for the installation and configuration of these devices.

This document is divided into three sections:

- PART 1: Device installation (wiring, power supply..)
- PART 2: EMS configuration in 11 steps
- PART 3: Help Section: Troubleshooting

## Disclaimer

This document is for general information only.

Elum Energy's commitments are defined in the applicable purchase contracts only, and are not affected by the content of this document.

This document is the property of Elum Energy and may not be reproduced, edited, or copied without prior written permission of Elum Energy.



## **PART 1. Device Installation**

<b>1. Elum device power supply</b>	<b>4</b>
Option A. Power supply when in kit	4
Option B. Power supply when in Elum casing	5
<b>2. Communication</b>	<b>6</b>
2.1. Internet connection	6
Option A. Cellular internet connection	6
Option B. Wired internet connection	6
2.2. Slave devices connection	7
Option A. Connecting devices through serial	7
Option B. Connecting devices through Ethernet	7
<b>HELP Section: Understanding the LEDs</b>	<b>8</b>

## **PART 2. EMS Configuration**

<b>Step 1-</b> Connecting the laptop to the Elum device	<b>9</b>
<b>Step 2-</b> Connecting to eConf (Elum Configuration interface)	<b>9</b>
<b>Step 3-</b> Internet configuration	<b>10</b>
<b>Step 4-</b> Software update	<b>11</b>
<b>Step 5-</b> Site settings	<b>12</b>
<b>Step 6-</b> Network configuration (ports)	<b>12</b>
<b>Step 7-</b> Network configuration (devices)	<b>13</b>
<b>Step 8-</b> Validation	<b>14</b>
<b>Step 9-</b> Data forwarding	<b>15</b>
<b>Step 10-</b> Control settings	<b>16</b>
<b>Step 11-</b> Saving the configuration and starting the EMS	<b>17</b>

## **HELP Section: Troubleshooting**

<b>Communication issues</b>	<b>18</b>
Serial Communication issues	18
Ethernet Communication issues	18
Internet Communication issues	19
<b>Reboot / Start issues</b>	<b>19</b>
<b>Reverse power protection issues</b>	<b>20</b>
<b>Power meter reading issues</b>	<b>20</b>

# PART 1 - DEVICE INSTALLATION

This chapter describes the product installation. It is important to finalize all the installation work before starting the configuration.



Please read carefully the safety instructions in the product [user manual](#) prior to installation.

## 1. Device power supply

This section describes the installation of the power supply for the Elum device when delivered in a kit (option A) and in Elum casing (option B). Please refer to the option relevant to your application.

### → Option A. Power supply when in kit

Elum devices require a power supply that can deliver the following:

Input Voltage	12 to 36 VDC
Power Consumption	50 W

Table 1: Elum devices power supply (in kit)

The Power supply connector is on the top side of the device:

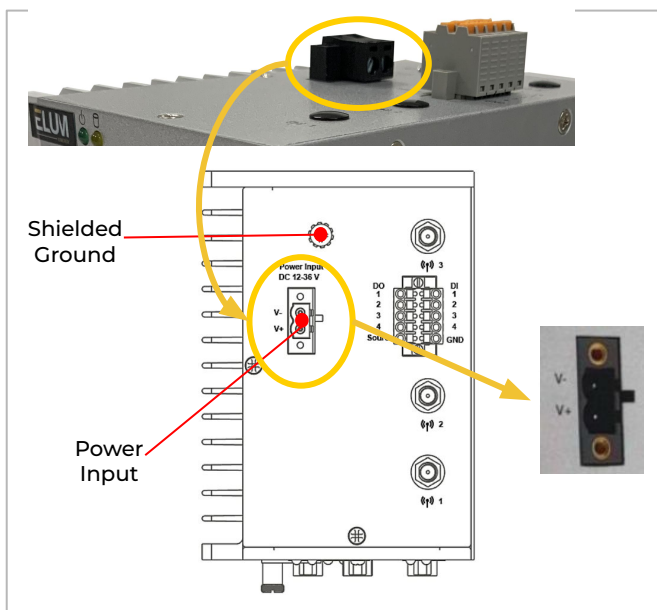

Figure 1: Elum device power input (in kit)

The Shielded Ground wire (Protected Ground) must be connected to an appropriate grounded metal surface.

Once the power supply is connected, the power LED will light up.

→ Option B. Power supply when in Elum casing

Elum devices require a power supply that can deliver the following:

Input Voltage	100 - 240 VAC, 50 Hz / 60 Hz
Power Consumption	50 W

Table 2: Elum devices power supply (in Elum casing)

The power connectors are wired to a single screw terminal block on the left side of the DIN Rail. Please follow the steps below to connect the power supply.

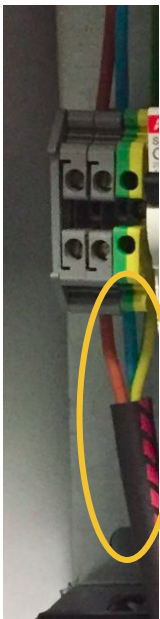

1. Connect the phase wire to the **red/brown** wire,
2. Connect the neutral wire to the **blue** wire,
3. Connect the ground wire to the **green/yellow** wire,
4. If a UPS was provided with the ePowerControl, connect the battery **red/black** wire to the transformer,
5. Close the circuit breaker, the power LED will light up.

Figure 2: Terminal block overview



For both options, the power source must be taken from the load side, to ensure a continuous power supply constantly.  
The power source of the UPS must follow the same rule.

After 60 seconds, the operating system will be ready, and the power LED will turn solid green.

Check that the Power LED of the Central Computing Unit is on. \_\_\_\_\_



# 2. Communication

## 2.1. Internet connection

Connecting the device to internet can be done in two ways:

### ➔ Option A. Cellular internet connection

- Turn off the Elum device.
- On the top side of the device, connect the three wireless antennas to the dedicated connectors.
- On the rear side of the device, open the cover of the SIM card slot with a screwdriver.
- Insert the SIM card. You'll hear a click.
- Close the cover.

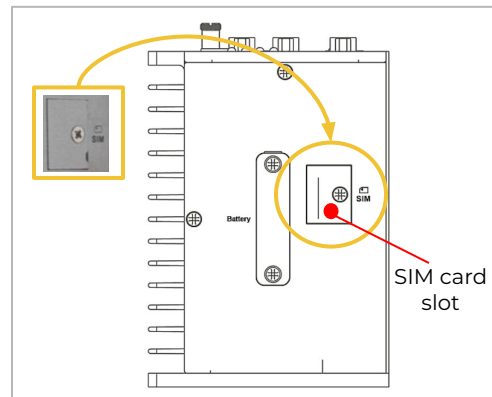
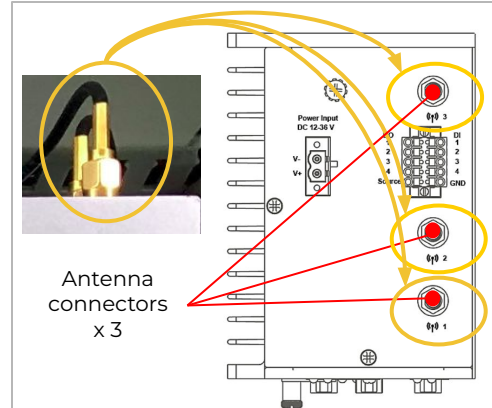

You may now turn on the Elum device.



The device must be turned off each time a SIM card is inserted or removed from the SIM card slot. In case of SIM card replacement, it is necessary to perform an empty start of the device.

### ➔ Option B. Wired internet connection

Elum devices can be connected to wired internet through the LAN port 1, 2 or 3.

A switch can be connected to each of the LAN ports if more ports are needed.

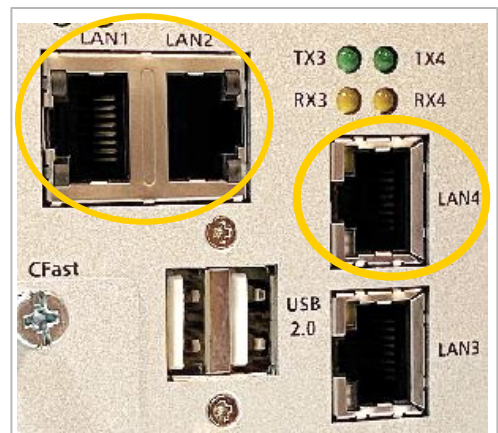



## 2.2. Slave devices connection

Slave devices can be connected either through serial and/or Ethernet. Please refer to the option relevant to your application.



For both options, it's highly recommended to use a surge protection to avoid any issues on the communication ports.

### ➔ Option A. Connecting devices through serial

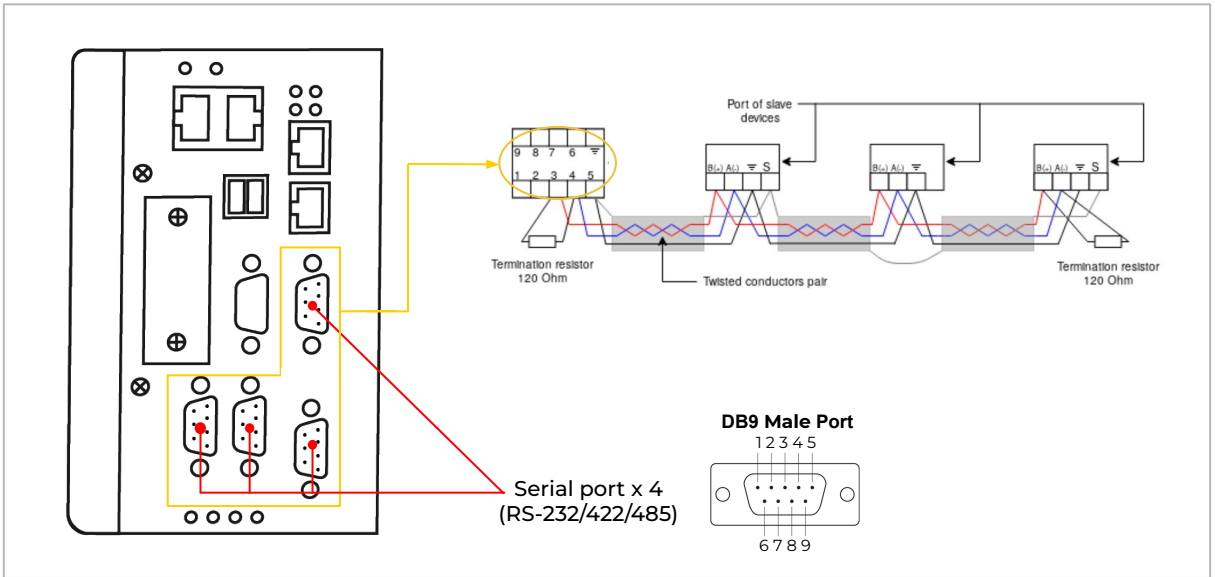
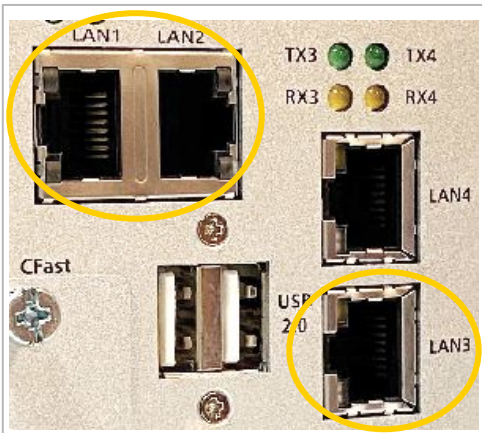

Figure 3 : Serial connection drawing

### ➔ Option B. Connecting devices through Ethernet



The slave devices can be connected through Ethernet to the Elum device using port LAN 1, 2 and 3. Use a RJ45 cable to connect the LAN to your device.

A switch can be connected to each of the LAN ports if more ports are needed.

# NEED ADDITIONAL HELP ?

## → Understanding the LEDs

When Elum devices are powered, all LEDs should be turned on for 1 second then off for 60 seconds (*internet connection and services starting*)

After 60 seconds, the color of the LEDs will help perform a quick diagnosis of the system behavior.

The table below shows the interpretation of the different case scenarios.











LED name	Status	Diagnosis
Power	Green 	Power is on. Normal operating mode.
	Off 	Power is off.
Storage	Yellow 	Blinking: Data is being transmitted.
	Off 	No data transmission.
LAN 1/2/3/4	Green 	100 Mbps Ethernet link. Blinking: Data is being transmitted.
	Yellow 	1000 Mbps Ethernet link. Blinking: Data is being transmitted
	Off 	10 Mbps Ethernet link or LAN is not connected.
Tx 1/2/3/4	Green 	Blinking: Data is being transmitted.
	Off 	LAN Not connected.
Rx 1/2/3/4	Yellow 	Blinking: Data is being received.
	Off 	LAN Not connected.

Table 3: LEDs diagnosis



# PART 2 - EMS CONFIGURATION

Once the installation is done, the configuration of Elum devices can start. Please follow the steps described below carefully.

## STEP 1 - CONNECTING THE LAPTOP TO ELUM DEVICE

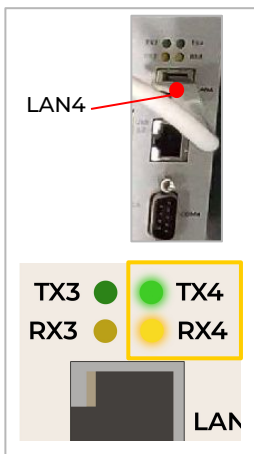

Connect the device to your computer, by connecting one end of a RJ45 cable to the Port LAN 4 of the device, and the other end to your computer.

Once the connection is established, the LEDs Tx4 & Rx4 indicator will flash on and off.

## STEP 2 - CONNECTING TO ECONF

Open your favorite browser, and login to eConf, Elum's configuration interface, by entering the following IP address: [192.168.4.127](http://192.168.4.127)

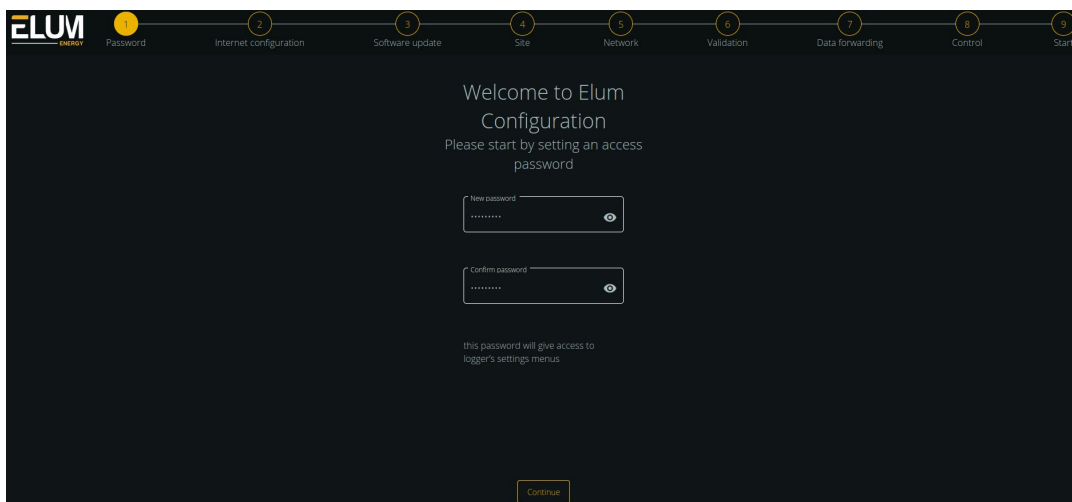

Enter the password of your choice.

It is recommended to use a strong password. (8 characters minimum, with a mix of alphabetical (upper and lowercase) numeric, and special characters)

Click "Continue".

## STEP 3 - INTERNET CONFIGURATION

Select the interface to use:

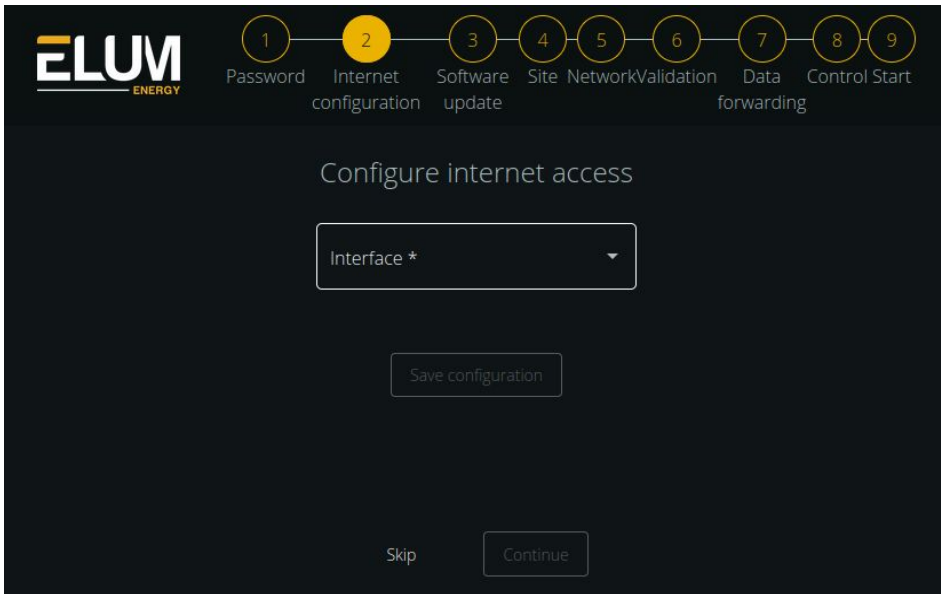

You can either connect through a SIM card:

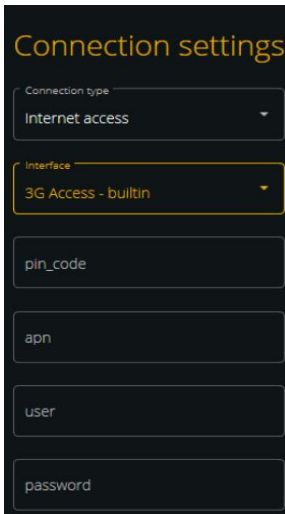

Or connect through an Ethernet network\*:

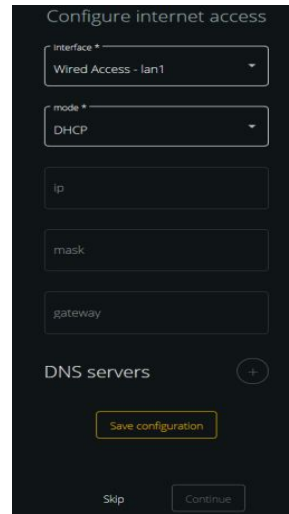

\* When connecting through Ethernet, please open the following **outgoing** ports. This is needed to connect the Elum device to our back end:

- **ICMP**
- **TCP ports: 53, 80, 443, all ports from 1198 to 1210, 4505 and 4506**
- **UDP ports: 53, 123, 1195, all ports from 1198 to 1210**

Click "Continue".

## STEP 4 - SOFTWARE UPDATE

eConf offers to install the latest firmware version on the device.  
Click “Check updates”. The latest version will appear if applicable.  
Click on the download icon to start.

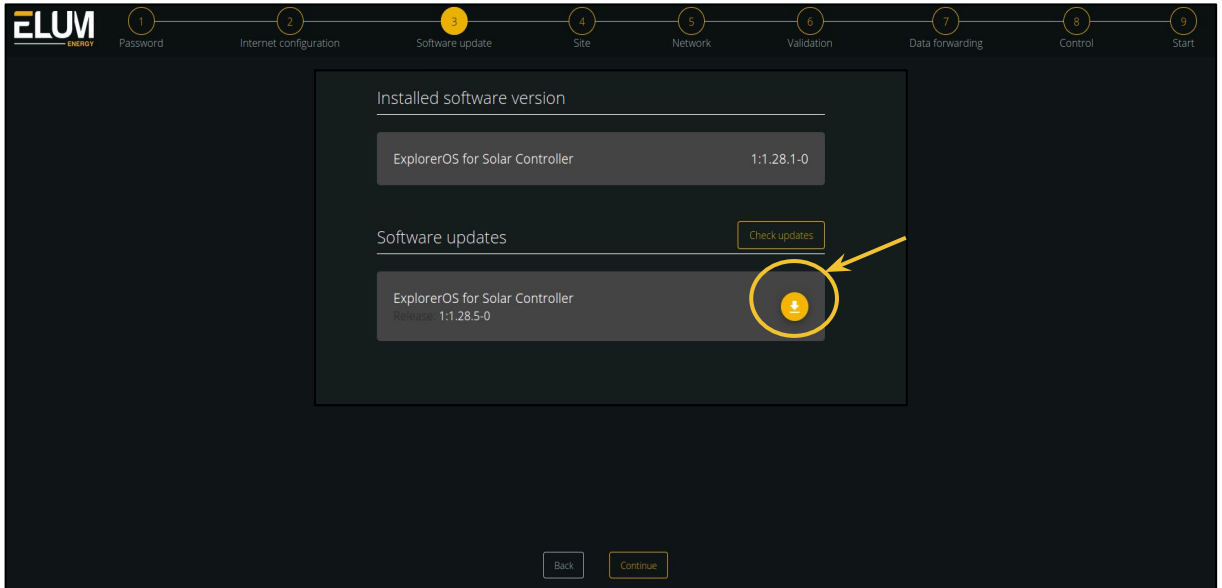

This process cannot be interrupted. Please ensure that the device remains on and connected to the internet to avoid any issues.

The device will automatically reboot once the update is done.  
The previous configurations should be retaken.



Click “Continue”.

## STEP 5 - SITE SETTINGS

Insert the name and GPS coordinates of the site.

The screenshot shows the ELUM ENERGY configuration interface. At the top, a progress bar indicates the current step is 5, 'Site', which is highlighted in yellow. The steps are: 1 Password, 2 Internet configuration, 3 Software update, 4 Site, 5 Network, 6 Validation, 7 Data forwarding, 8 Control, and 9 Start. The main content area is titled 'Site settings' and contains three input fields: 'Site name', 'Latitude', and 'Longitude'. Each field has a small location icon on the right side. At the bottom, there are three buttons: 'Back', 'Skip', and 'Continue'.

Click "Continue".

## STEP 6 - NETWORK CONFIGURATION (PORTS)

Click on "Configure a New Connection".  
Select the interface of the port (serial or ethernet)

The screenshot shows the ELUM ENERGY configuration interface for Step 6: Network configuration (ports). The progress bar at the top shows step 5, 'Network', highlighted in yellow. The main content area is titled 'Configure internet and device connections' and contains a text box with instructions: 'Click on "Configure a new connection" and follow the steps to configure an internet access or a device communication'. Below this, there is a 'Connection settings' dialog box with two dropdown menus: 'Connection type' (set to 'Device communication') and 'Interface'. At the bottom of the dialog are 'Cancel' and 'OK' buttons. In the background, there is a '+ CONFIGURE A NEW CONNECTION' button highlighted with a yellow box, and a yellow arrow points from it to the 'Connection settings' dialog. At the bottom of the main screen, there are 'Back' and 'Continue' buttons.

The port settings must be the same as the ones configured on the devices connected on it:

In case of serial devices :

Connection settings

Connection type  
Device communication

Interface  
Serial - serial-1

mode  
RS485

baudrate  
9600

parity  
NONE

Cancel OK

In case of Ethernet devices :

Connection settings

Connection type  
Device communication

Interface  
Wired access - lan1

mode  
DHCP

ip

mask

Cancel OK



Select “DHCP” for an automatic allocation of the IP address.  
Or “IP\_Static” to add the IP address and network settings manually.

Click “Ok”.

## STEP 7 - NETWORK CONFIGURATION (DEVICES)

Click on “Add device”, fill the boxes with the relevant information.  
Please ensure that the Modbus communication is enabled on all devices.



Please contact Elum support if the device you’re trying to connect is not listed, at [support@elum-energy.com](mailto:support@elum-energy.com).

### Adding the devices to the serial port

ELUM

1 Password 2 Internet configuration 3 Software update 4 Site 5 Network 6 Validation 7 Data forwarding 8 Start

Lan1 + ADD DEVICE

Serial-1 + ADD DEVICE

Device settings on serial-1

Device name \*

Vendor \*

Reference \*

Protocol \*

Cancel OK

## Adding the devices to the Ethernet port

## STEP 8 - VALIDATION

The connection to the devices can be tested:

On the Network page



One by one:

Or port by port:

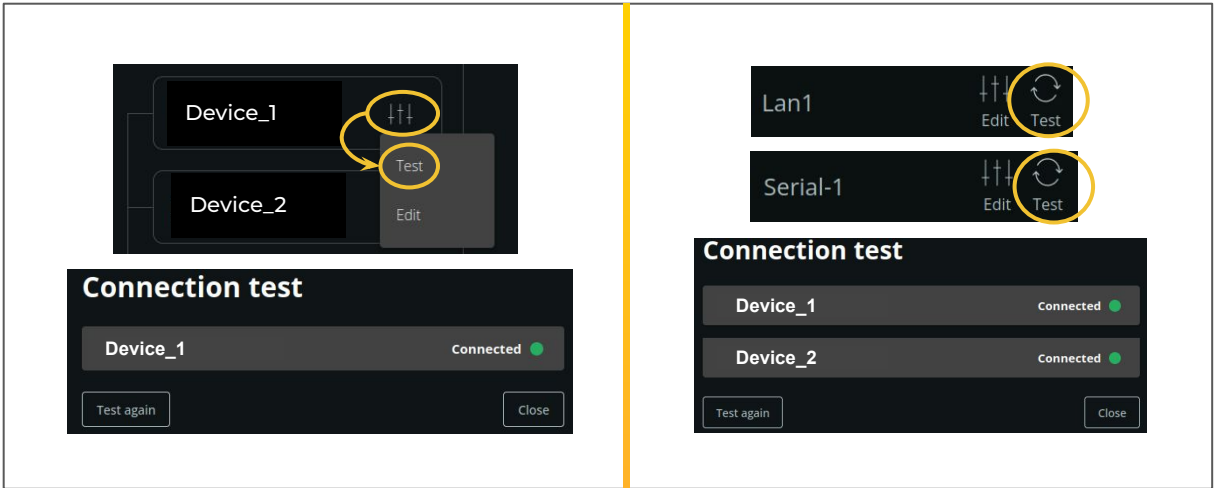

## On the Validation page

ELUM ENERGY

1 Password 2 Internet configuration 3 Software update 4 Site 5 Network 6 Validation 7 Data forwarding 8 Start

Make sure that all devices communicate properly and that the connection is stable. Click any device to check that values are retrieved.

Name	Reference	Type	Status
Genset	Genset	Genset controller	Connected
Load Meter	Power Meter	Power meter	Connected
Grid Meter	Power Meter	Power meter	Connected
Solar	Solar	Solar Inverter	Connected

Back Continue

Please ensure all devices are connected before moving to the next step.

## STEP 9 - DATA FORWARDING

Elum devices export data automatically to ePowerMonitor, the monitoring platform of Elum Energy.

In addition, Elum energy offers an option of exporting data to one or more third party monitoring platforms, or to USB devices.

This is the purpose of this tab.

You can configure the third party platform if applicable, or skip and move to the next page.

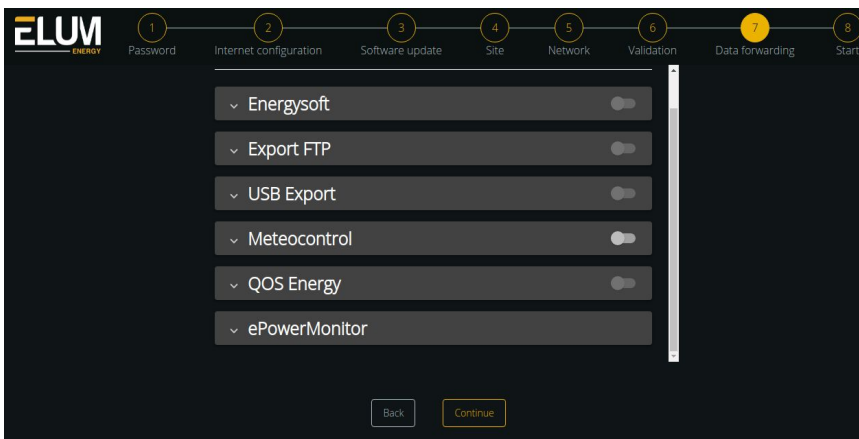

Click "Continue".

## STEP 10 - CONTROL SETTINGS

This tab is only available for ePowerControl (unavailable for ePowerLog)  
 Select the relevant application.  
 Add the relevant devices in their respective boxes.

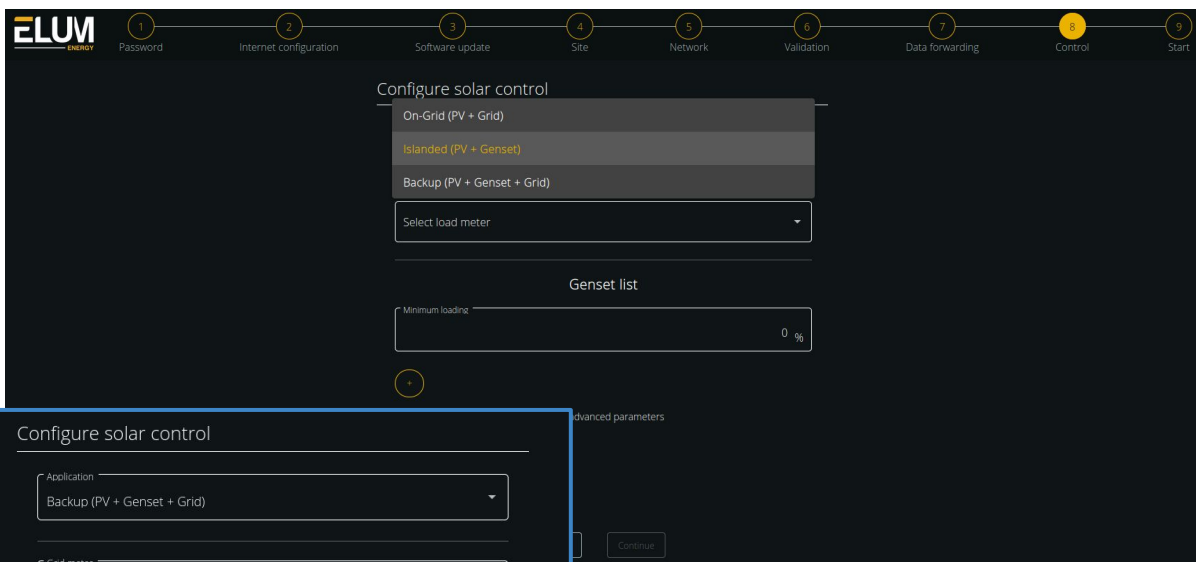

Application example

Click "Continue".

## STEP 11 - SAVING THE CONFIGURATION AND STARTING THE EMS

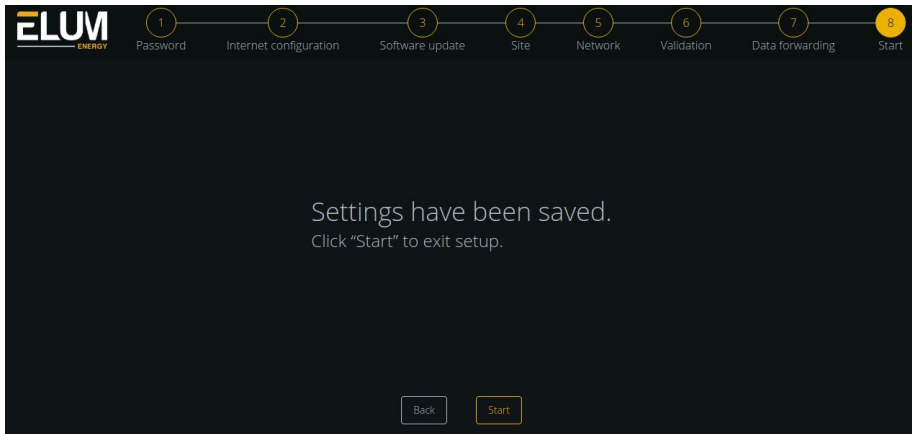

Once you click on the start button, the following page appears.

This is the final view of eConf.

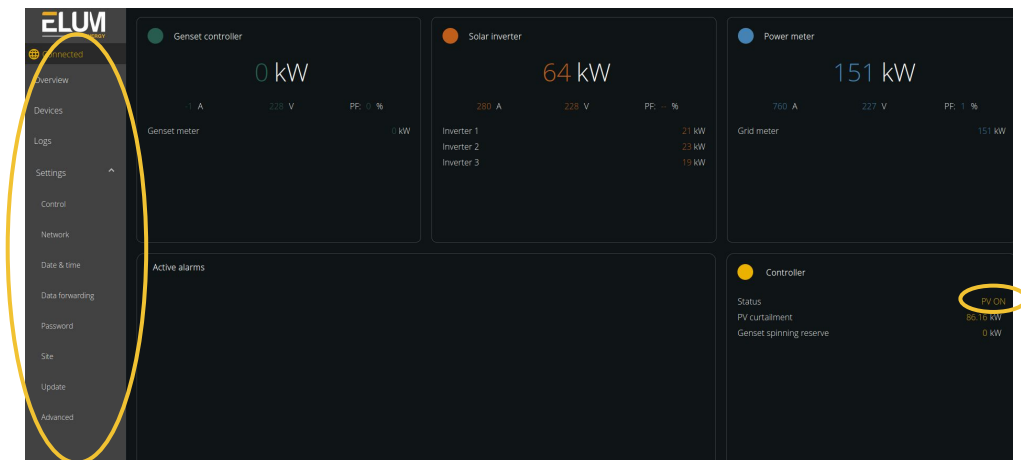

The overview page displays :

- the Active Power of the devices,
- The devices alarms when applicable,
- The Control Status,
- The PV curtailment (the sum of the setpoints sent by the controller to the inverters).

All the previous tabs can be accessible through the menu on the left. In order to make any modification, please stop the Control.

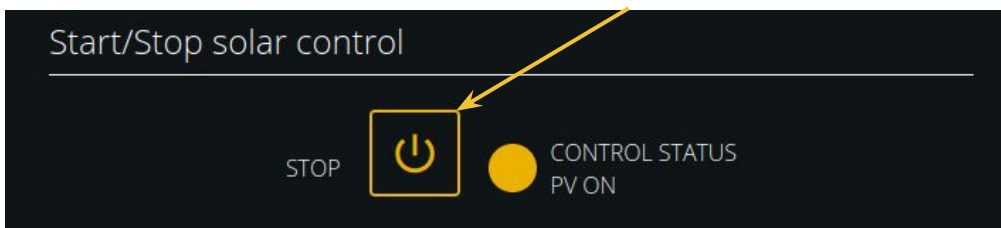

The EMS is now ready.

# TROUBLESHOOTING

The table below includes most common issues faced during the installation and configuration of Elum devices, the possible causes, and the steps to follow to solve them.

Issue	Possible causes	Steps to follow
<b>Serial Communication issues</b>		
Communication with the Serial device cannot be established	<ul style="list-style-type: none"> <li>- Modbus communication not enabled on slave device</li> <li>- Improper RS485 wiring</li> </ul>	<ul style="list-style-type: none"> <li>• Check the port and device communication settings both on eConf and the device itself.</li> <li>• Ensure the Modbus communication is enabled on the devices if applicable.</li> <li>• Ensure the RS485 wires are shielded twisted pairs.</li> <li>• Check the connectivity of the RS485 wires.</li> </ul>
Communication with the Serial device is intermittent	<ul style="list-style-type: none"> <li>- Neglected RS485 wiring</li> </ul>	<ul style="list-style-type: none"> <li>• Ensure the RS485 cables are correctly inserted and fixed in the pins.</li> <li>• Check that the RS485 cables are correctly stripped and protected by the sheathing to the pins.</li> <li>• Check that the distance for serial communication is less than 1000m.</li> <li>• Add a termination resistance (120 Ohm) on each end of the RS485 line.</li> </ul> <p>Please refer to the <a href="#">Device Connection &amp; Configuration document</a>, for specific instructions.</p>
<b>Ethernet Communication issues</b>		
Communication with the device through Ethernet cannot be established	<ul style="list-style-type: none"> <li>- Modbus communication not enabled on slave device</li> </ul>	<ul style="list-style-type: none"> <li>• Check the port and device communication settings both on eConf and the device itself.</li> <li>• Ensure the Modbus communication is enabled on the devices if applicable.</li> </ul>
Communication with the device through Ethernet is intermittent	<ul style="list-style-type: none"> <li>- IP address conflict</li> </ul>	<ul style="list-style-type: none"> <li>• Ensure no IP address is used more than once.</li> </ul> <p>Please refer to the <a href="#">Device Connection &amp; Configuration document</a>, for specific instructions.</p>

Issue	Possible causes	Steps to follow
<b>Internet Communication issues</b>		
Local internet access fails	Local internet network configuration invalid	<ul style="list-style-type: none"> <li>Please refer to <a href="#">the note on step 3</a>, for wired internet connection configuration.</li> </ul>
Wireless internet network fails	SIM card contract invalid	<ul style="list-style-type: none"> <li>The GSM/3G kit is pre-embedded in the Central Computing Unit. You also need a SIM card with a subscription to a valid “data” contract.</li> </ul> <p>Please refer to <a href="#">paragraph 2.1. Option A</a> for more details.</p>
<b>Reboot / Start issues</b>		
Elum Controller reboots when switching from “On grid - Grid connected mode” and to “Off grid - Genset connected mode”.	<ul style="list-style-type: none"> <li>- Unstable power source</li> <li>- Incorrect UPS wiring</li> </ul>	<ul style="list-style-type: none"> <li>The power source supplying the Datalogger / Controller must be taken from the load side, to ensure a continuous power supply constantly.</li> <li>If a UPS is used, the power source of the UPS must follow the same rule as above.</li> </ul>
Elum Controller reboots when switching from “Off grid - Genset connected mode” to “On grid - Grid connected mode”.		<p><i>For ePowerControl HFS the use of a UPS is mandatory.</i></p>

Issue	Possible causes	Steps to follow
<b>Reverse power protection issues</b>		
Wrong breaker control	<ul style="list-style-type: none"> <li>- Missing Reverse power protection relay</li> <li>- Incorrect configuration of the Reverse power protection relay</li> </ul>	<p>ePower Control is NOT an electrical protection. It does not replace an adequate protection of diesel generators against power reversal.</p> <p>Please install a dedicated Reverse power protection relay, or a genset controller integrating the reverse current protection function.</p> <p>Please refer to the manufacturer documentation for proper configuration of the relay.</p>
Breaker control fails		
<b>Power meter reading issues</b>		
Power meter monitoring values are incorrect	Incorrect Power meter VTs/CTs ratios	<ul style="list-style-type: none"> <li>• CT ratio: Can be obtained by dividing the primary current by the secondary current.</li> <li>• VT ratio : Can be obtained by dividing the primary voltage by the secondary voltage.</li> </ul>
Cos phi is incorrect, All the other power meter monitoring values are correct	Incorrect Power meters VTs/CTs wiring	<ul style="list-style-type: none"> <li>• Rearrange CTs and VTs wiring by respecting phases order.</li> </ul>
Power meter monitoring values signs are incorrect	Negative power monitoring not enabled on grid meter	<ul style="list-style-type: none"> <li>• The meter must be a bidirectional one.</li> <li>• Check the configuration of the power meter (measurement type).</li> <li>• Check the CTs installation, which must match the current direction.</li> </ul> <p><i>Please refer to the manufacturer documentation for proper configuration of the relay.</i></p>



More Resources are available on: [www.elum-energy.com](http://www.elum-energy.com)  
For more details, you can contact our customer service team at [support@elum-energy.com](mailto:support@elum-energy.com)..