



Troubleshooting and maintenance



Agenda

Troubleshooting common issues

- 1) Unreachable
- 2) Disconnected or unstable device connection
- 3) CRC errors
- 4) Modbus invalid slave ID error
- 5) PV Curtailment
 - a) Verifying inverter nominal power configuration
 - b) Generator readings
 - c) Reactive power management & Power factor

Troubleshooting common issues

1) Unreachable

Troubleshooting protocol for RTU communication :

- For compatible RS-485 devices, connect them to either serial port 1 or 2 on the ePowerControl.

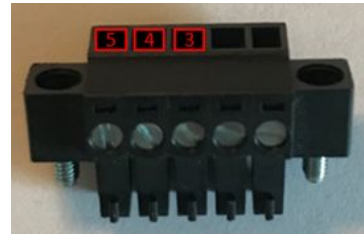
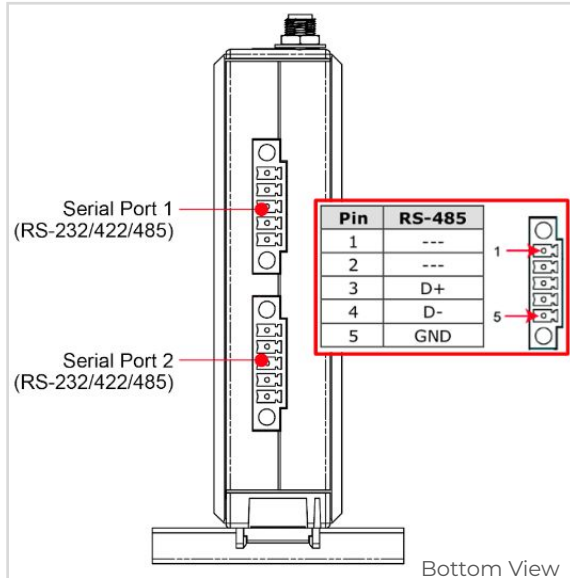

Pin	RS-232	RS-422	RS-485
1	TXD	TXD+	---
2	RXD	TXD-	---
3	RTS	RXD+	D+
4	CTS	RXD-	D-
5	GND	GND	GND

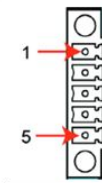

Ensure :

- that cables are properly inserted and securely fixed in the pins.
- That the cables are correctly stripped and that the sheathing is intact up to the pins.
- that the cable length does not exceed 1000 meters.

Troubleshooting common issues

1) Unreachable

Troubleshooting protocol for RTU communication :

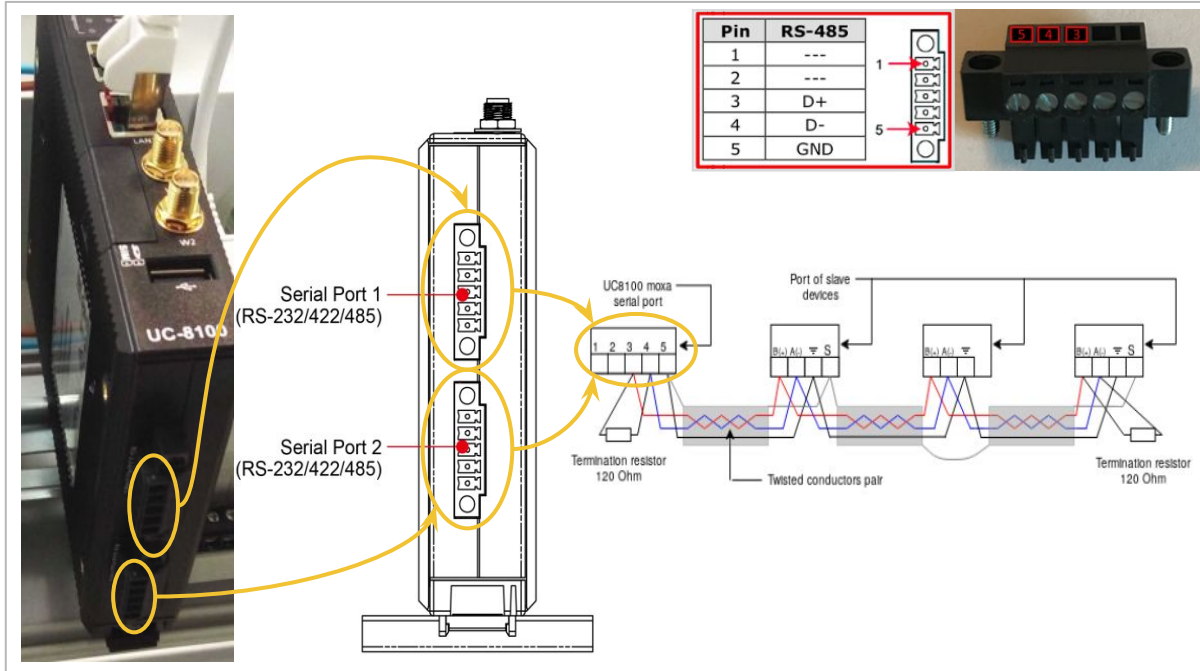

- 1) Ensure the cable used is a **shielded twisted pair**.
- 2) Verify that the **D(+)** and **D(-)** cables are from the **same twisted pair** and follow the pinout specified in the manufacturer's manual.
- 3) **Pin 3** of the serial port should be connected in a daisy chain to all the **DataB(+)** ports of the devices.
- 4) **Pin 4** of the serial port should be connected in a daisy chain to all the **DataA(-)** ports of the devices.
- 5) **Pin 5** of the serial port should be connected in a daisy chain to all the **GND** ports of the devices.

Troubleshooting common issues

1) Unreachable

Troubleshooting protocol for RTU communication :

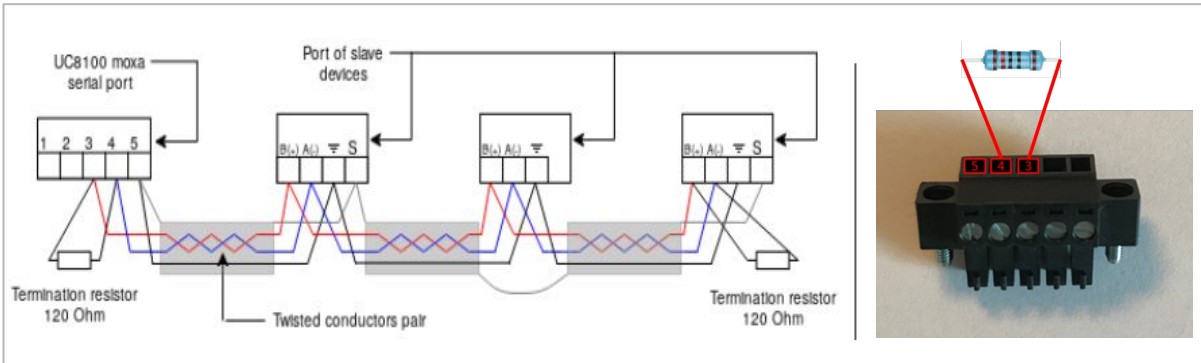

1) Make sure to connect the **termination resistors** between **DataB(+)** and **DataA(-)** (as shown in the figure). Ensure that the resistors match the impedance of the communication cable, typically **120 Ohms**.

2) Ensure the **shielding** is continuous across all serial lines and connects to the **GND** wire of the RS-485 circuit at the controller (**Pin 5**).

3) Confirm that the **shielding** is connected only at the controller level with the GND wire, as specified, to prevent ground loops.

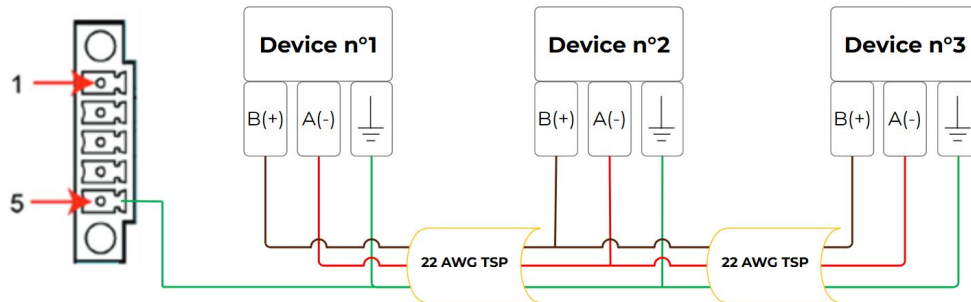

Troubleshooting common issues

1) Unreachable

Troubleshooting protocol for RTU communication :

⇒ Modbus parameter verification :

Verify that the device's Modbus parameter settings align with the configuration specified on the controller:

- **Baud rate:** 2400, 4800, 9600, 19.2k, 38.4k, 57.6k, or 115.2k bps
- **Parity mode:** Even, Odd, or None
- **Stop bits:** 1 or 2
- **Response timeout:** 0–1000 ms (default is 0.5 ms)
- **Modbus slave ID:** Address range from 1 to 247 (default is 247)

Note: Ensure that each device on the same serial line has a unique ID.

The image shows two side-by-side configuration panels. The left panel, titled 'Device settings on serial-1', contains the following fields: 'Device name*' (Device n°1), 'Vendor*' (Huawei), 'Reference*' (SUN2000-100KTL-H0), 'Protocol*' (MODBUS_RTU), 'slave_id*', 'response_timeout' (0.5), 'byte_timeout' (0.1), and 'inter_frame_delay' (10). The right panel, titled 'Connection settings', contains: 'Connection type*' (Device communication), 'Interface*' (Serial - serial-1), 'mode*' (RS485), 'baudrate*' (9600), 'parity*' (NONE), 'byte_size*' (8), and 'stop_bits*' (ONE). Both panels have 'Cancel' and 'OK' buttons at the bottom.

Troubleshooting common issues

1) Unreachable

Troubleshooting protocol for TCP communication :

- Elum devices can connect to **wired internet** through **LAN port 1** using an **RJ45 cable**.
- **LAN 1** is dedicated to **Ethernet connections** for devices, and if additional LAN ports are required, a **switch** can be added to LAN 1.
- Verify the **pin configuration** and ensure the RJ45 cable is intact and securely connected.



Pin	Signal
1	ETx+
2	ETx-
3	ERx+
6	ERx-

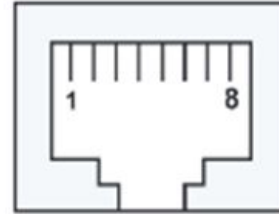

LAN 2 is reserved exclusively for configuration purposes.

Troubleshooting common issues

1) Unreachable

Troubleshooting protocol for TCP communication :

⇒ Modbus parameters verification :

Ensure the device's Modbus parameters match the configuration on the controller, and confirm that the IP address is valid:

- **DHCP Mode:** Verify that the IP address falls within the correct subnet range and is unique, ensuring it isn't already assigned to another device on the network.
- **Static IP Mode (Fixed IP):** Confirm that the device's IP address is within the same subnet range as the Ethernet port where it's connected.

The screenshot displays two panels of a network configuration interface. The left panel, titled 'Connection settings', includes a 'Connection type*' dropdown set to 'Device communication', an 'Interface*' dropdown set to 'Wired access - lan1', a 'mode*' dropdown set to 'DHCP', and input fields for 'ip*', 'mask*', 'gateway', and 'name_servers'. The right panel, titled 'Device settings on lan1', includes a 'Device name*' dropdown set to 'Device n*1', a 'Vendor*' dropdown set to 'Huawei', a 'Reference*' dropdown set to 'SUN2000-100KTL-H0', a 'Protocol*' dropdown set to 'MODBUS_TCP', and input fields for 'ip*', 'port' (502), 'slave_id' (1), and 'response_timeout' (0.5). Below these are two checkboxes: 'Protect IP from concurrent access' and 'Keep the TCP sessions open between requests', both of which are checked. Both panels have 'Cancel' and 'OK' buttons at the bottom.

Troubleshooting common issues

2) Disconnected or unstable device connection

⇒ Go to the **"All Devices" tab** on eConf to view the communication status of all components, including PV inverters, meters, genset controllers, and BESS.

- If any device appears as **"Disconnected"**, it may indicate incorrect RTU/TCP parameters or a configuration mismatch with Elum's products
- Verify RTU and TCP parameters:
 - **RTU parameters:** Cross-check the **Slave ID**, **Baud Rate**, and **Parity** on the **"Disconnected"** device with the settings in eConf.
 - **TCP parameters:** Ensure the device is on the same subnet as the Elum Explorer, avoiding IPs in the **192.168.4.XX** range. Verify that the subnet mask matches the one used by Elum Explorer.

Status
Disconnected
Connected



Troubleshooting common issues

3) CRC errors

Understanding CRC errors in RTU communication :

⇒ **Definition:** CRC (Cyclic Redundancy Check) errors occur in Modbus RTU communication, indicating potential data issues.

- The device detects bit activity, confirming a physical connection on the communication line.
- Despite receiving data, the information is unintelligible to the device, likely due to corruption or configuration mismatches.

⇒ **Key points to understand:**

- **Communication is established:** The device recognizes a data packet and performs a CRC check, confirming a connection.
- **Data integrity issue:** The CRC check passes, but the data itself is misinterpreted or invalid, so the device can't respond properly.

⇒ **Specific to RTU Protocol:**

Occurs only with RTU (binary form) data transmission, making it more prone to errors from improper wiring, grounding, or mismatched settings (e.g., baud rate, parity, stop bits).

Troubleshooting common issues

3) CRC errors

Troubleshooting protocol for RTU communication :

⇒ Go to the "Logs" tab on eConf to identify any unwanted disconnections affecting setpoints sent by Elum.

- Confirm that the correct driver (reference) is selected for the device.
- **Verify Baud Rate and character format:** Confirm that the device's baud rate and character format match the controller's configuration.
- **Ensure compliance with wiring guidelines:** Verify that the RS-485 wiring follows the guidelines discussed in the first point to avoid misconfigurations.
- **Check shielding integrity:**
 - **Inspect wire labeling:** Verify that the wire meets recommended specifications for capacitance, resistance, and conductor count.
 - **Grounding of shield:** Ensure the shield is grounded at only one point on the RS-485 chain and maintains continuity across the entire daisy chain.

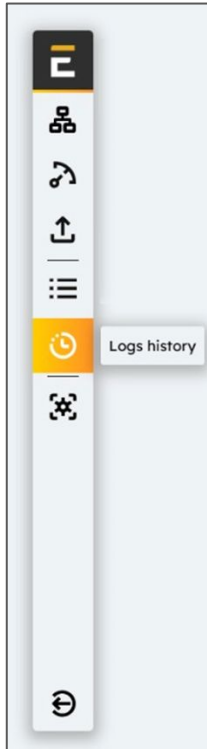

Troubleshooting common issues

3) CRC errors

Troubleshooting protocol for RTU communication :

- ⇒ **Test shield continuity:** Using a multimeter, test the continuity between the shield and earth ground, starting from the ungrounded end, to confirm proper grounding setup. The point here is to read a very low resistance, as shown in the following diagram.

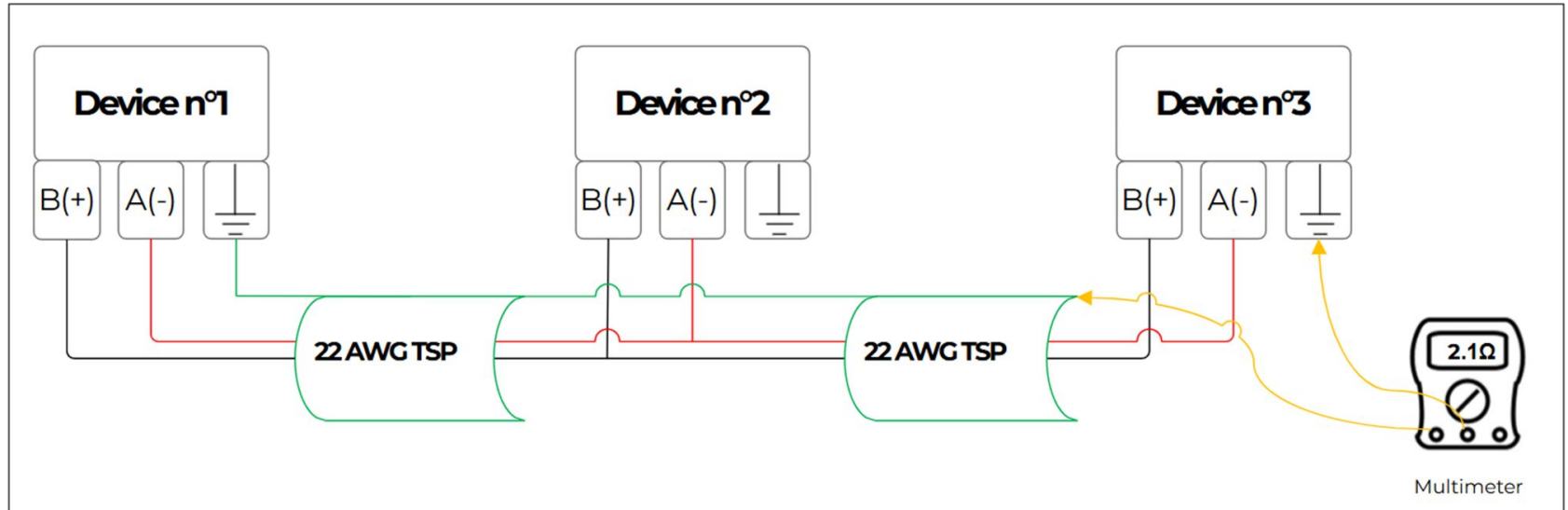

Troubleshooting common issues

3) CRC errors

Troubleshooting protocol for RTU communication :

⇒ **Test shield continuity:** At the opposite end of the daisy chain, check that the shield is physically connected to the ground. Perform the same test, but this time disconnect the shield wire from its ground connection. When tested with a multimeter, it should read as an open circuit to earth ground, as shown in the following diagram.

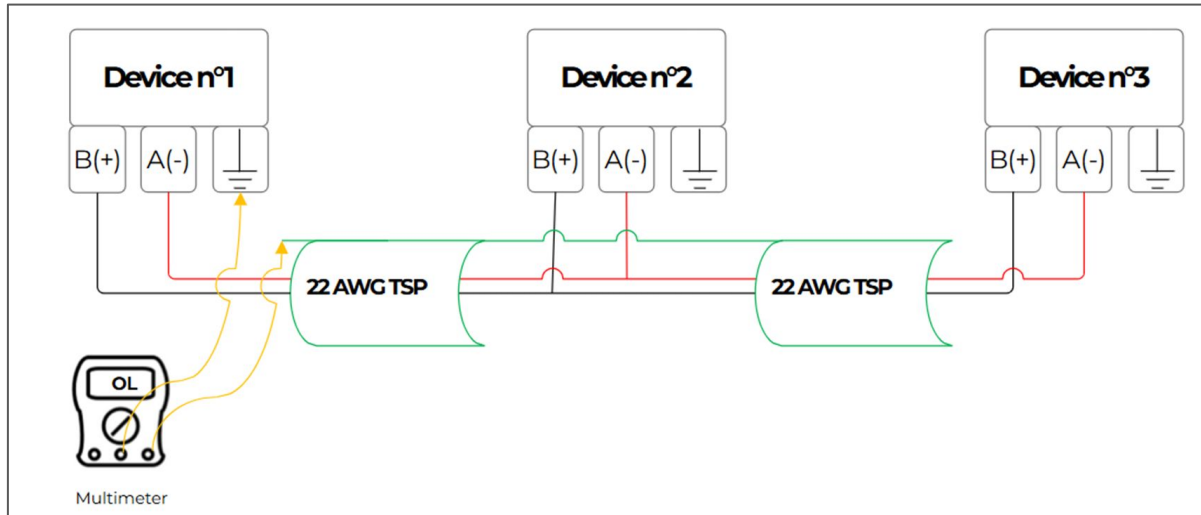

If "OL" (open load) doesn't appear, multiple grounding points may exist. Ensure only the shield's start is grounded. Then, reconnect it to ground at the first device only.

Troubleshooting common issues

4) Modbus invalid slave ID error

Troubleshooting protocol for RTU communication :

In a network, each slave device has a unique address. When the master sends a data request, it includes the slave's address as the first piece of information. This allows each slave to recognize immediately if the message is meant for them or if they should ignore it.

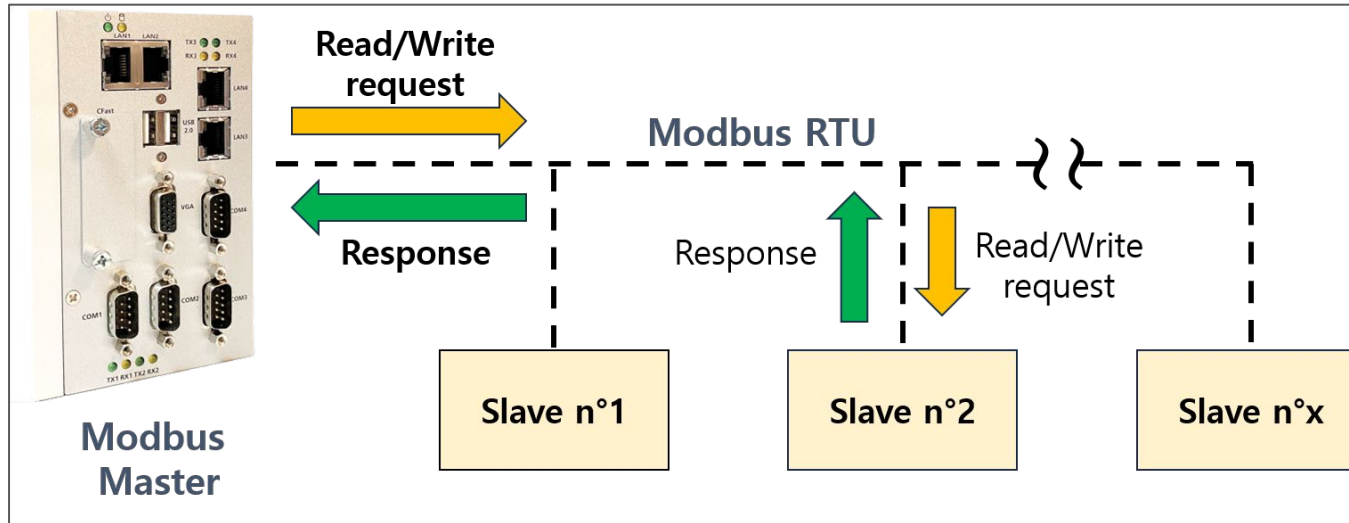

⇒ Ensure there is only one master device, typically the ePowerControl ES+ unit, on the line.

Troubleshooting common issues

5) PV curtailment

Verifying inverter nominal power configuration

⇒ Check Firmware Version

- Go to the “Settings” tab on eConf.
- Navigate to “Update” or “Firmware” to check the firmware version of your controller.

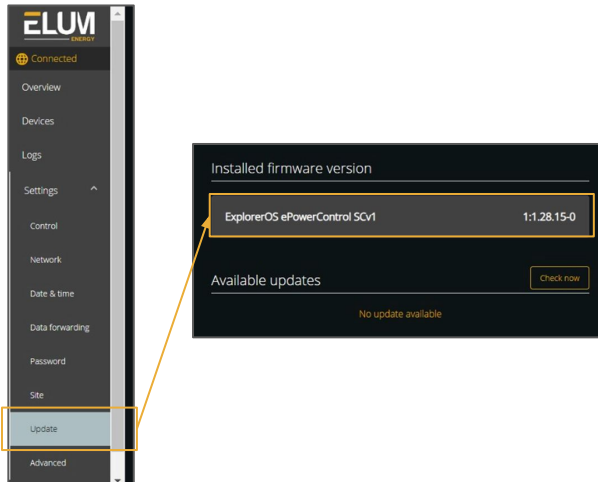

Scv1

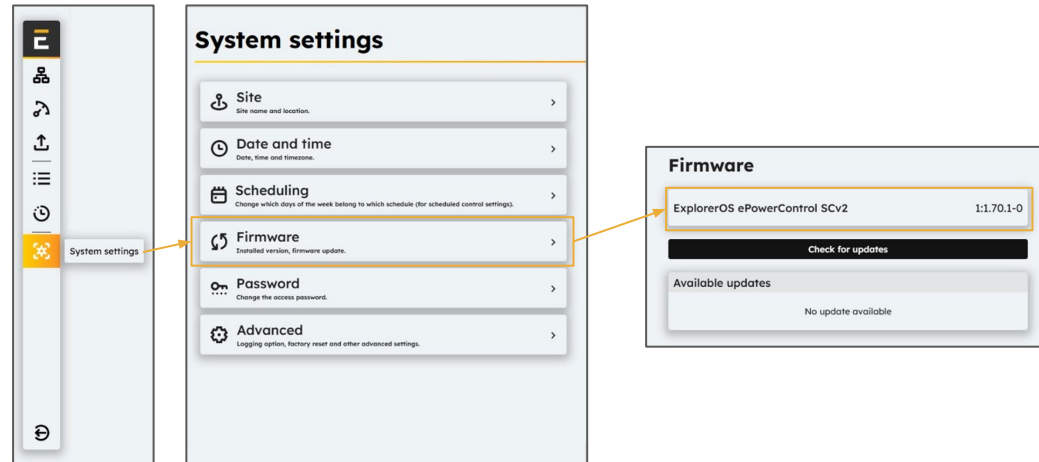

Scv2

Troubleshooting common issues

5) PV curtailment

Verifying inverter nominal power configuration

For Scv1 :

Go to “Settings” > “Network” and verify that the selected reference aligns with the inverter’s specifications.

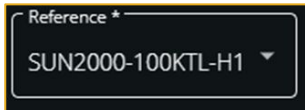

⇒ with the Huawei SUN2000-100KTL-H1 inverter, the '100K' label indicates a rated active power of 100,000 W.

⇒ The on-site connected power must match the rated power configured in eConf and correspond to the inverter connections. Any mismatch between the configured power and connected load may lead the EMS to limit production for optimal performance

For Scv2 :

Go to “Control” > “PV Control” and check that the Inverter’s rated apparent power matches its specifications.

Inverters rated apparent power values	
PV Inverter 2	100 kVA
PV inverter 1	100 kVA
PV inverter 3	100 kVA

⇒ The correct rated apparent power value, according to the inverter's factory specifications, should be entered in the system.

Troubleshooting common issues

5) PV curtailment

Verifying Genset minimum loading in eConf

- ⇒ Navigate to "Genset Control" and check the fixed minimum loading value for the genset.
 - Confirm that this minimum load is being met; if not, the PV system will not ramp up to protect genset operation.

The image displays two screenshots from the ELUM Energy management system interface, separated by a vertical yellow bar.

For ScV1 : The left screenshot shows the 'Settings' menu with 'Control' selected. An arrow points to the 'Genset list' screen, which displays 'Minimum loading' at 30 %.

For ScV2 : The right screenshot shows the 'Control' menu selected. An arrow points to the 'Genset control' screen, which then leads to the 'Genset minimum loading' screen. This screen shows 'Genset 1' with a minimum loading of 15 %.

- ⇒ If the client's consumption falls below the genset's fixed minimum load, the PV system should hold back from ramping up to maintain safe genset operation.

Troubleshooting common issues

5) PV curtailment

Generators reading

For ScV1 :

- ⇒ In the "Control" section, go to "Grid control":

If the "3x Lowest Phase" method is selected and one phase consistently shows a low reading, the system will set a low peak shaving reference. This may lead to unnecessary PV curtailment, even if total grid power is high, as the system limits output based on the low phase to maintain balance.

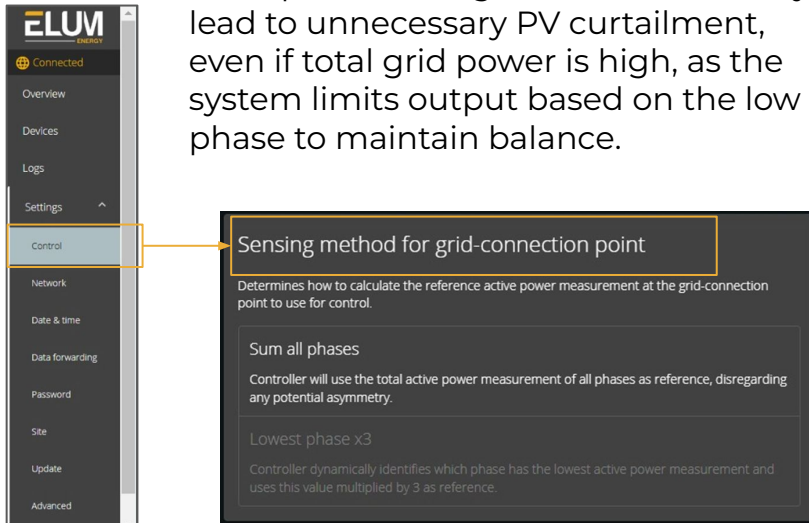

Sensing method for grid-connection point
Determines how to calculate the reference active power measurement at the grid-connection point to use for control.

- Sum all phases**
Controller will use the total active power measurement of all phases as reference, disregarding any potential asymmetry.
- Lowest phase x3**
Controller dynamically identifies which phase has the lowest active power measurement and uses this value multiplied by 3 as reference.

For ScV2 :

- ⇒ In the "Control" tab, go to the "Genset meters" section and adjust the "unit detection method" (either frequency or percentage of rated power threshold) according to the site specifications.

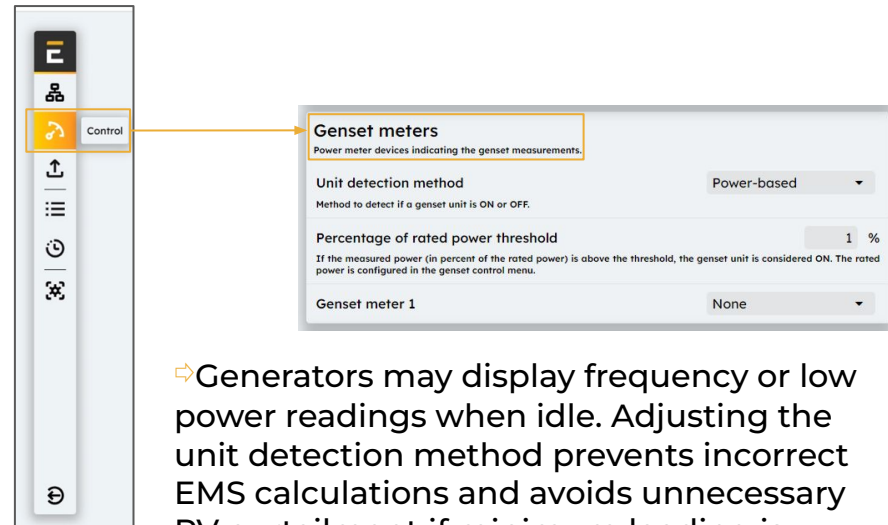

Genset meters
Power meter devices indicating the genset measurements.

- Unit detection method**
Method to detect if a genset unit is ON or OFF. Power-based
- Percentage of rated power threshold**
If the measured power (in percent of the rated power) is above the threshold, the genset unit is considered ON. The rated power is configured in the genset control menu. 1 %
- Genset meter 1**
None

- ⇒ Generators may display frequency or low power readings when idle. Adjusting the unit detection method prevents incorrect EMS calculations and avoids unnecessary PV curtailment if minimum loading is unmet.

Troubleshooting common issues

5) PV curtailment

Reactive power management & Power factor

⇒ Reactive power management or power factor correction, if prioritized, can disrupt site operations by altering power flow dynamics.

- In the “Control” tab on eConf, check if any of these options are enabled. If they are, disable them and monitor the system’s behavior.

- **PV Control :**

Prioritize reactive power production over active power production

- **Grid & Genset Control :**

The screenshot shows a configuration panel for reactive power control. At the top, there is a toggle switch for 'Activate Reactive Power Control' which is currently turned on. Below this, the 'Controlled units' section lists 'PV' and 'BESS', each with a toggle switch and a 'kVAR' input field. The 'PV' unit is currently disabled, while 'BESS' is enabled. The 'Leading control unit' is set to 'PV'. The 'Reactive power control strategy' is set to 'Power Factor Range'. At the bottom, there are input fields for 'Minimum Capacitive Power Factor' and 'Minimum Inductive Power Factor'.

Controlled units	Units used to perform genset reactive power control.	Toggle	Unit
PV		<input type="checkbox"/>	kVAR
BESS		<input checked="" type="checkbox"/>	kVAR

Leading control unit: PV

Reactive power control strategy: Power Factor Range

Power Factor Range Based Reactive Power Control

The configured unit is controlled so that the power factor of the gensets stays within configured power factor range.

Minimum Capacitive Power Factor: [input field]

Minimum Inductive Power Factor: [input field]